

Transmission System Guidelines



Xcel Energy Operating Companies

Interconnection Guidelines for Transmission Interconnected Customer Loads

Version: 13.0

File Name: XEL-POL-TransmissionInterconnectedCustLoads Version 13 - FINAL (10-2-23).docx

Page 1 of 49

1.0 PURPOSE

- This guideline describes the requirements for connecting a customer's new load or modifying an existing interconnection to an electric transmission line or substation owned and operated by one of the Xcel Energy operating companies: Northern States Power Company (Minnesota) and Northern States Power Company (Wisconsin) (jointly NSP); Public Service Company of Colorado (PSCo); and Southwestern Public Service Company (SPS).

2.0 APPLICABILITY AND RESPONSIBILITIES

- Xcel Energy Services Inc., the service company for the Xcel Energy Inc. holding company system.
- Xcel Energy Operating Companies.

3.0 APPROVERS

Name	Title
Anthony Jandro	Area Vice President, Transmission Portfolio Delivery
Cory Wood	Senior Director, Transmission
David Berklund	Regional Vice President, NSP Transmission
TBD	Regional Vice President, PSCo Transmission
Amanda R. King	Director, Strategic Transmission Planning
Brian R. Lorentz	Director, Transmission Asset Management

4.0 VERSION HISTORY

Date	Version Number	Supersedes	Change
8/23/2010	3.0	N/A	Initial ProjectWise Document.
8/28/2013	4.0	3.0	General review and update. Updated language on Power Factor. Updated language on metering. Added language regarding Special Protection Systems.
10/1/2013	4.1	4.0	Made corrective changes to the document.
8/29/2014	5.0	4.1	General review and update.
8/31/2015	6.0	5.0	Annual review and update
8/31/2016	7.0	6.0	Annual review and update
8/31/2017	8.0	7.0	Annual review and update
8/31/2018	9.0	8.0	Annual review and update
8/31/2019	10.0	9.0	Annual review and update
8/31/2020	11.0	10.0	Annual review and update
11/3/2022	12.0	11.0	Annual review and update
8/31/2023	13.0	12.0	Annual review and update

Transmission System Guidelines



Xcel Energy Operating Companies

Interconnection Guidelines for Transmission Interconnected Customer Loads

Version: 13.0

File Name: XEL-POL-TransmissionInterconnectedCustLoads Version 13 - FINAL (10-2-23).docx

Page 2 of 49

Transmission System Guidelines



Xcel Energy Operating Companies

Interconnection Guidelines for Transmission Interconnected Customer Loads

Version: 13.0

File Name: XEL-POL-TransmissionInterconnectedCustLoads Version 13 - FINAL (10-2-23).docx

Page 3 of 49

Policy

A. INTRODUCTION	6
B. THE XCEL ENERGY SYSTEMS.....	6
C. GUIDELINE AUTHORITY.....	8
D. GUIDELINE OBJECTIVES AND LIMITATIONS	9
E. INTERCONNECTION PROCESS.....	9
F. FINANCIAL OBLIGATION OF THE CUSTOMER.....	10
G. OWNERSHIP, OPERATION.....	11
H. OPERATION SUBJECT TO TRANSMISSION OPERATOR.....	11
I. NERC AND RRO POLICIES AND STANDARDS COMPLIANCE.....	11
J. REGULATORY APPROVALS AND PERMITS.....	12

II.INTERCONNECTION TECHNICAL REQUIREMENTS 12

A. INTERCONNECTION CONFIGURATION.....	12
B. MODELING INFORMATION	13
C. SEPARATE SYSTEMS	14
D. PARALLEL OPERATION OF GENERATION.....	14
E. PROTECTIVE DEVICES	14
F. INTERFERENCE.....	15
G. VOLTAGE, HARMONICS, AND FLICKER.....	15
F. FREQUENCY AND FREQUENCY CONTROL.....	16
H. EMERGENCY LOAD SHED OBLIGATION	17
I. MINIMUM POWER FACTOR REQUIREMENTS	18
J. FAULT CURRENT.....	19
K. DISCONNECT DEVICE/POINT OF DEMARCATION.....	19
L. EFFECTIVE GROUNDING	21

III.EQUIPMENT, PROTECTION AND CONTROL REQUIREMENTS 21

A. FAULT CLEARING.....	21
B. UTILITY GRADE RELAYS	21
C. MINIMUM PROTECTION REQUIREMENTS.....	22
D. REDUNDANT/BACKUP PROTECTION	22
E. SYNCHRONIZATION.....	22
F. STATION POWER/STATION SERVICES	23
G. GROUNDING SYSTEM	23

Transmission System Guidelines



Xcel Energy Operating Companies

Interconnection Guidelines for Transmission Interconnected Customer Loads

Version: 13.0

File Name: XEL-POL-TransmissionInterconnectedCustLoads Version 13 - FINAL (10-2-23).docx

Page 4 of 49

H. CONTROL, PROTECTION, AND COMMUNICATION INTERCONNECTIONS.....	23
I. COMMUNICATION CHANNEL (S).....	23
J. METERING AND TELEMETRY	23
K. SUPERVISORY CONTROL AND DATA ACQUISITION (SCADA)	24
L. VOLTAGE AND BIL VALUES	24
N. REMEDIAL ACTION SCHEME.....	24

IV. LOAD INTERCONNECTION PROCESS 24

A. TRANSMISSION SERVICE REQUEST	24
B. TRANSMISSION LOAD INTERCONNECTION REQUESTS STEPS	25

V. ACCEPTANCE TESTING AND INSPECTION REQUIREMENTS 28

A. GENERAL.....	28
B. DEMONSTRATION.....	29
C. FUTURE CHANGES IN REQUIREMENTS	31
D. PERFORMANCE OF TESTS	31
E. TESTING EQUIPMENT	31
F. XCEL ENERGY SUPPLIED EQUIPMENT	32
G. FINAL DESIGN/AS-BUILT DOCUMENTS	32

VI. OPERATION AND MAINTENANCE GUIDELINES 32

A. NORMAL CONDITIONS.....	32
B. ABNORMAL CONDITIONS	32
C. ENERGIZATION OF XCEL ENERGY EQUIPMENT BY THE CUSTOMER	33
D. MAINTENANCE NOTIFICATION.....	33
E. MAINTENANCE	33
F. DESIGN CHANGES AFTER COMMERCIAL OPERATION	34
G. OPERATING DATA SUBMITTALS	34
H. OPERATIONAL LOG.....	34
I. COMMUNICATION WITH XCEL ENERGY OPERATIONS.....	34

VII. GLOSSARY 35

VIII. REFERENCES 41

APPENDIX A: TYPICAL INTERCONNECTION CONFIGURATION 43

APPENDIX B: XCEL ENERGY METERING AND TELEMETRY REQUIREMENTS 46

1. GENERAL.....	46
2. METERING ACCURACY, TESTING, AND REPAIR	46

Transmission System Guidelines



Xcel Energy Operating Companies

Interconnection Guidelines for Transmission Interconnected Customer Loads

Version: 13.0

File Name: XEL-POL-TransmissionInterconnectedCustLoads Version 13 - FINAL (10-2-23).docx

Page 5 of 49

3. METERING AND TELEMETRY FUNCTION REQUIREMENTS47

Transmission System Guidelines	
 Xcel Energy	Xcel Energy Operating Companies
Interconnection Guidelines for Transmission Interconnected Customer Loads	Version: 13.0
<i>File Name:</i> XEL-POL-TransmissionInterconnectedCustLoads Version 13 - FINAL (10-2-23).docx	Page 6 of 49

I. INTRODUCTION AND GENERAL POLICY

A. Introduction

The Interconnection Guidelines for Transmission Interconnected Customer Loads (**Guidelines**) describe the requirements for connecting new or additional loads to an electric transmission system owned and operated by any of the following Xcel Energy operating companies: Public Service Company of Colorado (**PSCO**), Southwestern Public Service Company (**SPS**), or Northern States Power Company (Minnesota) or Northern States Power Company (Wisconsin) (jointly **NSP**). For the balance of this document, the Xcel Energy utilities will be jointly referred to as **Xcel Energy** or the **Xcel Energy Operating Companies**.

These Interconnection Guidelines are to comply with the requirements of NERC reliability standard FAC-001, Facility Interconnection Requirements, by maintaining and publishing facility interconnection requirements.

These Guidelines should thus be considered a "User's Guide" to the interconnection process for Customers and Xcel Energy employees. To the extent possible, the Guidelines provide a universal set of requirements for all Xcel Energy transmission systems. However, there are some technical requirements specific to a state, Xcel Energy operating company or North American Electric Reliability Corporation (**NERC**) **Reliability Region**. The specific requirements are discussed in more detail below, where applicable. Each such requirement is labeled with the Operating Company or Reliability Organization to which it applies.

In this document, certain words and abbreviations are identified as having specific meanings. These words and abbreviations are given in **bold face** type when initially defined. These words and abbreviations can also be found in the **GLOSSARY** section of this document.

For example, for purposes of these Guidelines, the term **Customer** will be used to refer to transmission connected end use loads. To the extent any of the Xcel Energy operating companies construct and own facilities serving loads and propose to interconnect to the Xcel Energy transmission system, it will also be considered a Customer with regards to the new projects.

B. The Xcel Energy Systems

1. Description of Xcel Energy Operating Companies

The Xcel Energy Operating Companies own and operate electric transmission systems in portions of 10 states. The applicable states are:

- NSP - Minnesota, North Dakota, South Dakota, Wisconsin, Michigan
- PSCO - Colorado
- SPS - Texas, New Mexico, Kansas, Oklahoma

The following is a simple map showing the location of the transmission systems of each Xcel Energy Operating Company.

Transmission System Guidelines



Xcel Energy Operating Companies

Interconnection Guidelines for Transmission Interconnected Customer Loads

Version: 13.0

File Name: XEL-POL-TransmissionInterconnectedCustLoads Version 13 - FINAL (10-2-23).docx

Page 7 of 49

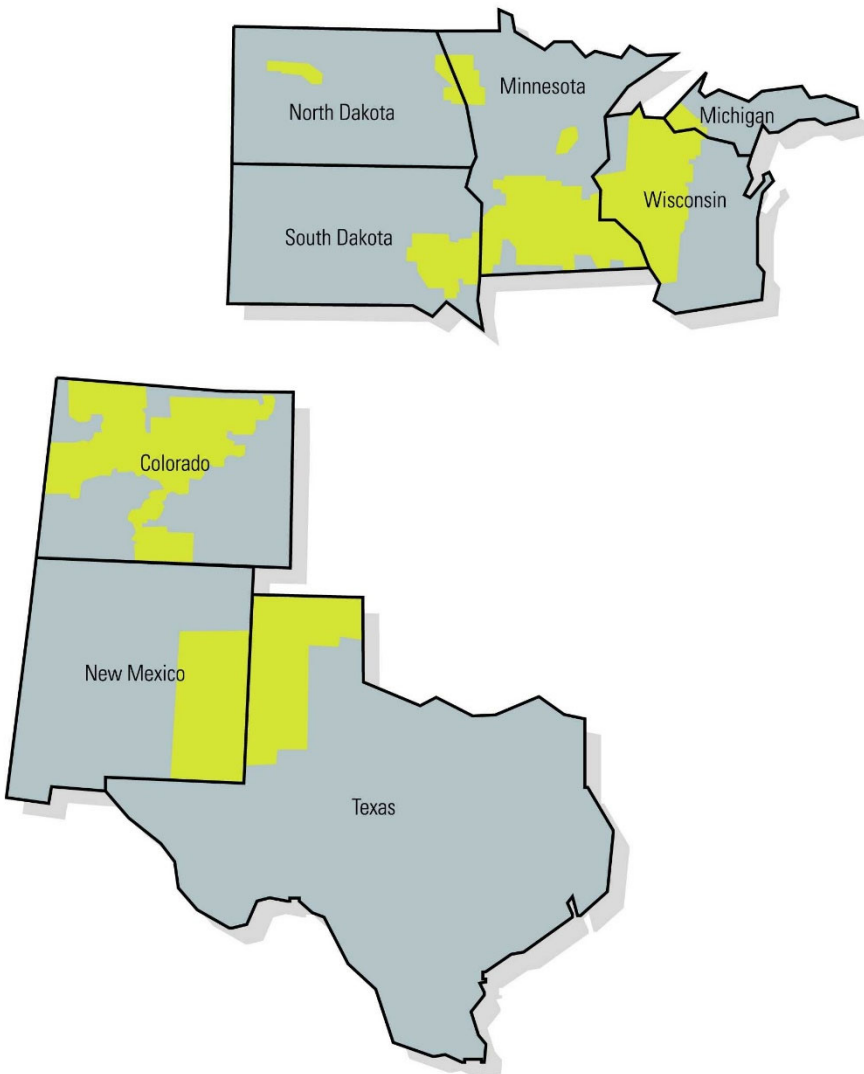

Other electric utilities also serve these states, and in some areas the utilities operate highly interconnected networks. A Customer must determine if the proposed interconnection will in fact interconnect to a transmission facility owned by an Xcel Energy operating company at the proposed location. If the interconnection will interconnect to a transmission facility owned by another utility, these Guidelines are not applicable.

2. Reliability Regions

The Xcel Energy Operating Company transmission systems are located in two **NERC Reliability Regions**. Each Reliability Region has certain requirements that are specific to that region. NERC has delegated authority for Reliability Standard enforcement to the Regional Entities overseeing the various Reliability Regions. The two Regional Entities applicable to Xcel Energy are the Midwest Reliability Organization (**MRO**), and the Western Electricity Coordinating Council (**WECC**). The applicable Reliability Regions for each of the Xcel Energy Operating Companies are as follows:

Transmission System Guidelines



Xcel Energy Operating Companies

Interconnection Guidelines for Transmission Interconnected Customer Loads

Version: 13.0

File Name: XEL-POL-TransmissionInterconnectedCustLoads Version 13 - FINAL (10-2-23).docx

Page 8 of 49

- NSP - MRO <https://www.mro.net/>
- PSCO - WECC www.wecc.org

3. OPEN ACCESS TRANSMISSION TARIFFS (OATT)

The Xcel Energy transmission systems are also subject to three different **OATTs** on file with the FERC. The NSP system is a member of the Midcontinent Independent System Operator, Inc. (MISO or Midcontinent ISO) regional transmission organization (RTO). The SPS system is a member of the SPP RTO. Each RTO has an OATT on file with FERC.

The Applicable OATT, and the web site addresses, are as follows:

- NSP - the MISO regional OATT, the MISO Open Access Transmission, Energy, and Operating Reserves Market Tariff (MISO OATT) available at www.misoenergy.org (click on "Tariff" Quick Link)
- PSCO - the Xcel Energy Operating Companies Joint OATT, is available at the Xcel Energy web site (www.xcelenergy.com); Xcel Energy > Transmission > Open Access Transmission Tariff
- SPS - SPP regional OATT (**SPP OATT**), available at http://www.spp.org/publications/SPP_Tariff.pdf (click on "Regional Tariff" in the matrix of selections)

As indicated above, these Guidelines should be considered supplemental technical requirements to the procedures and requirements set forth in the applicable OATT. To the extent there is a conflict between these Guidelines and the applicable OATT, the applicable OATT will control unless FERC has accepted the Xcel Energy Guideline. Note for NSP and SPS, there are explicit discussions of the interconnection processes in the Xcel Energy Joint OATT and the SPP Tariff respectively.

C. Guideline Authority

Several federal and state regulatory agencies have authority over the electric services provided by the Xcel Energy operating companies. The requirements set forth by this document are intended to comply with these requirements, including the Federal Power Act (**FPA**), all local, state, and federal regulatory agency requirements, and the applicable requirements of other entities related to owners and operators of electric systems, such as NERC or the Regional Reliability Organization. The Customer should keep abreast of changes in regulatory requirements and comply with them as they develop. Specifically:

FERC has authority over any interconnection to an Xcel Energy electric transmission system at transmission voltage under the FPA. The Final Rules, and the individual OATTs implementing them (listed above), are subject to change from time-to-time. The Customer should consult the applicable OATT to ensure that the most up to date OATT requirements are used in the project design, operation, and maintenance requirements.

NERC has established standards and practices for the reliable design and operation of the electric transmission system. NERC and the individual Reliability Regions modify and update their requirements from time to time. The Customer should also consult the websites of NERC (www.nerc.com) and the applicable Reliability Region (see above) to ensure that the most up-to-date requirements are used in the project design, operation, and

Transmission System Guidelines	
 Xcel Energy	Xcel Energy Operating Companies
Interconnection Guidelines for Transmission Interconnected Customer Loads	Version: 13.0
<i>File Name:</i> XEL-POL-TransmissionInterconnectedCustLoads Version 13 - FINAL (10-2-23).docx	Page 9 of 49

maintenance requirements. This Guideline is periodically updated, but the Guideline may not reflect the most up-to-date information.

Various American National Standards Institute (**ANSI**) and Institute of Electrical and Electronic Engineers (**IEEE**) standards affect interconnection of facilities and are mentioned in this Guideline. ANSI and IEEE update and revise these standards from time to time. The Customer should plan its load interconnection using the latest revision of referenced ANSI/IEEE standards because Xcel Energy considers them to be automatically incorporated into this Guideline.

The NSP and SPS transmission systems are part of the MISO and SPP **RTOs**, respectively. For the purposes of this document, the term **RTO**, unless specified otherwise, will be used to refer to such regional transmission entities. As such changes occur, the requirements imposed on Xcel Energy by the applicable RTO will affect the interconnections. Xcel Energy plans to update these Guidelines from time-to-time to incorporate the changing RTO requirements that become applicable, but the Interconnection Customer should consult the ISO for any applicable RTO requirements.

However, these Guidelines are not intended to modify any existing OATT, other tariffs, or agreements that establish the rights and obligations of Xcel Energy or the Customer. This document also is not intended to override or change any statutes, regulations, or other applicable authority. In cases where national, Reliability Organization, or state, or local codes or regulations are in conflict with the provisions of these Guidelines, the national, state, or local code will take precedence.

Since these Guidelines are subject to these various regulatory authorities, who are subject to change, Xcel Energy reserves the right to revise these Guidelines from time-to-time without advance notice.

D. Guideline Objectives and Limitations

These Guidelines serve as a reference for establishing Xcel Energy/Customer interconnection to operate a load connection in parallel with an Xcel Energy electric transmission system (**Xcel Energy System**). The technical terms used in this guide are defined in the **GLOSSARY**.

These Guidelines are formulated to provide the Customer with a reliable interconnection while providing Xcel Energy with the flexibility and authority necessary to preserve reliability. All of the elements necessary for Xcel Energy to achieve this flexibility will normally be under the control of Xcel Energy. All of the elements necessary for the Customer to control, operate, and maintain its facilities will generally be under the control of the Customer. The objective is a clear line or point of demarcation between the Xcel Energy and the Customer's equipment, maintenance, and operating responsibilities.

Any responsibilities and liabilities between Xcel Energy and the Customer will be detailed in the interconnection agreement between Xcel Energy and the Interconnection Customer (or between the applicable RTO, Xcel Energy Operating Company and the Interconnection Customer). The terms "approve", "approved", and "approval" used throughout this document mean acceptance. "Approval" by Xcel Energy does not mean that Xcel Energy endorses or is held responsible for the safety or reliability of a Customer's design and facility.

E. Interconnection Process

The process for a Customer to connect a load to the Xcel Energy System is described in Section IV.

Transmission System Guidelines



Xcel Energy Operating Companies

Interconnection Guidelines for Transmission Interconnected Customer Loads

Version: 13.0

File Name: XEL-POL-TransmissionInterconnectedCustLoads Version 13 - FINAL (10-2-23).docx

Page 10 of 49

Interconnection requests will only be considered on existing transmission facilities or transmission facilities that have been identified as committed to in a state filing, OASIS posting, or Regional Transmission Organization (RTO) approved transmission plan (ex. MISO MTEP appendix A or B only, SPP Integrated Transmission Plan).

If the proposed facility is RETAIL load anywhere in Xcel Energy Service territory.

Retail Transmission load interconnection requests are taken through the Xcel Energy Sales Account Representatives; If you are unsure who your Account Representative is, contact the Business Solutions Center and they can help you identify your Representative. Xcel Energy Business Solutions Center 1-800-481-4700.

If the proposed WHOLESALE load serving facility to be interconnected to the NSP, PSCO, or SPS transmission system.

This location currently takes load interconnection requests through the Transmission Business Relations Department; Current contact information for the three areas (NSP- Minneapolis, PSCO – Denver, SPS – Amarillo) can be found on the Xcel Energy website (<http://www.transmission.xcelenergy.com/Interconnections>).

Limitation: As determined by FERC, a request for interconnection of a load **does not** constitute a request for transmission service. The process described in these Guidelines is not sufficient, nor intended, to determine the capability of the transmission network to deliver the Customer desiring transmission service from Xcel Energy or the appropriate ISO, including a system impact study if one is necessary, must follow the procedures of the Xcel Energy OATT or the appropriate ISO OATT in requesting transmission service.

F. Financial Obligation of the Customer

The Customer will reimburse Xcel Energy fully for the costs to interconnect the facilities.

The following are examples, but not a complete list of Interconnection Costs:

1. Study analyses and related expenses to determine:
 - a. The feasibility to interconnect;
 - b. The transmission facilities required for interconnection;
 - c. The Xcel Energy System upgrades required for the interconnection;
 - d. Construction and project schedules; and
 - e. Cost estimates and other related information.
2. Preparation of and presentation of study results to appropriate regional oversight committees or planning groups.
3. Land and rights-of-way, including any required licensing or permitting.
4. The Customer's Interconnection Facilities.
5. Meter installation, testing, and maintenance, including all parts and other related labor.
6. Meter reading and scheduling.
7. Telemetry installation, testing, and maintenance, including all parts and other related labor.
8. Operating expenses, including communication circuits.
9. Xcel Energy protective device installation, testing, equipment cost, and related labor.
10. Customer's protective device and review of design, inspection, and test witnessing.

Any cost responsibilities detailed in the load interconnection agreement between Xcel Energy and the Customer that conflict with this section will take precedence over these Guidelines.

Transmission System Guidelines	
 Xcel Energy	Xcel Energy Operating Companies
Interconnection Guidelines for Transmission Interconnected Customer Loads	Version: 13.0
<i>File Name:</i> XEL-POL-TransmissionInterconnectedCustLoads Version 13 - FINAL (10-2-23).docx	Page 11 of 49

G. Ownership, Operation

Xcel Energy will normally own and operate all transmission facilities constructed for the interconnection of a Customer's facilities to the Xcel Energy System that are determined to be part of the transmission system. Xcel Energy shall own all Xcel Energy Interconnection Facilities and System Upgrades that Xcel Energy determines that it is appropriate to own. This includes, but is not limited to, revenue meters, relaying, control systems, breakers, switches, bus work, and transmission lines. Xcel Energy may, at its option, contract with the Customer or a third party for construction of any or all of these facilities.

The Customer will normally construct and own, at a minimum all Customer Interconnection Facilities, unless the parties agree in the interconnection agreement that Xcel Energy will construct these facilities.

If the Customer plans to contract with Xcel Energy to operate or maintain the Customer's Interconnection Facilities, specific design considerations may be required that go beyond the minimum technical requirements described in this document. To ensure the safety of Xcel Energy personnel and to minimize the opportunity for human error, the Customer may be required to use certain Xcel Energy design standards and criteria or certain approved equipment manufacturers which may include but are not limited to: control panel layouts, ground grid designs, personal ground attachments placed in approved locations, electrical clearances, and lighting of the electrical equipment for night operating. The Customer will pay for the training of Xcel Energy personnel, if required, to operate and maintain this Customer-owned equipment. The Customer will be required to maintain their own stock of any necessary spare/emergency parts and make them available to Xcel Energy maintenance personnel or contract employees.

All equipment, whether provided by Xcel Energy or the Customer, whose operation or failure can result in the separation of an Xcel Energy System, must conform to the technical specifications of this Guideline. All Xcel-owned or -operated equipment or devices must be accessible at all times to Xcel Energy personnel.

H. Operation Subject To Transmission Operator

Operation of all interconnected transmission equipment must be under the direction of a NERC-certified **Transmission Operator**. NSP, PSCO and SPS are each NERC-certified Transmission Operators.

However, the Xcel Energy balancing and/or transmission operating areas are not contiguous with the Xcel Energy Systems. In some cases, Xcel Energy owns transmission facilities in the balancing and/or transmission operating area operated by another entity. Similarly, other utilities own transmission facilities within the Xcel Energy balancing and/or transmission operating area. Xcel Energy will operate (switch) all equipment that it owns, or which is considered integral to the Xcel Energy System and is within an Xcel Energy balancing and/or transmission operating area. At its option, Xcel Energy may contract with another Balancing Area or Transmission Operator to provide for any or all of its operation requirements for transmission lines that Xcel Energy owns but are located outside of an Xcel Energy balancing and/or transmission operating area.

I. NERC and RRO Policies and Standards Compliance

As discussed in Section II.D., all interconnections operated normally in long term parallel with the Xcel Energy System must satisfy NERC policies and standards and the applicable Regional Entity's (MRO or WECC) standards including providing data and other information. The interconnecting Customer and Xcel Energy must agree on how the Customer will accomplish these requirements. The Customer must agree to assist Xcel Energy in

Transmission System Guidelines	
 Xcel Energy	Xcel Energy Operating Companies
Interconnection Guidelines for Transmission Interconnected Customer Loads	Version: 13.0
<i>File Name:</i> XEL-POL-TransmissionInterconnectedCustLoads Version 13 - FINAL (10-2-23).docx	Page 12 of 49

determining the interconnection’s compliance with the NERC and the Regional Entity’s policies and standards and provide such information as required by NERC or the Reliability Region. For purposes of compliance with NERC Reliability Standards or compliance with other applicable NERC Regional Entity requirements, Xcel Energy will be responsible for ownership and operating compliance for the facilities it owns while the Interconnection Party will be responsible for ownership and operating compliance for the facilities it owns unless Xcel Energy explicitly agrees in writing to take that responsibility.

All Interconnections must provide evidence that they have agreement with entities that identify the NERC defined Balancing Authority, Transmission Operator, Transmission Planner, Resource Planner, Transmission Owner, and Planning Coordinator.

Upon notification of interconnection request Xcel Energy will confirm with the applicable Transmission Operations group that the new or qualified change to the transmission facilities is within the NSP, PSCO or SPS Balancing Authority Area. If the qualified change to the transmission facilities is not within the NSP, PSCO or SPS Balancing Authority Area, Xcel Energy will notify the Interconnection Customer.

J. Regulatory Approvals And Permits

The schedule for interconnection and commercial operation of a new customer load depends on obtaining regulatory approvals and permits for construction of required facilities. Interconnection facilities and system upgrades typically require several permits and regulatory approvals.

The Customer is responsible for obtaining all required permits and regulatory approvals for its interconnection facilities. Xcel Energy is responsible for obtaining approval for the permits and regulatory approvals necessary for any Xcel Energy Interconnection Facilities or System Upgrades. The Customer's responsibility for the cost of Xcel Energy's permits and regulatory approvals will be determined by the applicable OATT.

In addition, regulatory approvals may be required to be obtained by neighboring systems if interconnection of the Customer’s generator will make it necessary for system upgrades to be constructed on these systems.

The lead-time for obtaining these regulatory approvals and permits is often lengthy. This lead-time should not be underestimated.

II. INTERCONNECTION TECHNICAL REQUIREMENTS

The technical requirements in this document apply to all Customer load equipment interconnected with the Xcel Energy System. This applies to all distribution substations and associated transmission tap lines. If you have questions, please contact Xcel Energy. Contact information can be found at the Xcel Energy web site (www.xcelenergy.com), (http://www.xcelenergy.com/Company/Transmission/Transmission_Organizations/Interconnections_for_Transmission).

A. Interconnection Configuration

An interconnecting Customer may interconnect at an existing Xcel Energy substation or an existing Xcel Energy transmission line. The substation configuration requirements of the interconnection depend on where the physical interconnection is to occur and the performance of the system with the proposed interconnection.

Transmission System Guidelines	
 Xcel Energy	Xcel Energy Operating Companies
Interconnection Guidelines for Transmission Interconnected Customer Loads	Version: 13.0
<i>File Name:</i> XEL-POL-TransmissionInterconnectedCustLoads Version 13 - FINAL (10-2-23).docx	Page 13 of 49

Xcel Energy uses standard substation configurations in various parts of its system for serving load: T-Tap, Single Bus, Ring Bus, Main & Transfer Bus, Double-bus, and Breaker-and-a-half Bus design. If the Customer interconnects to an existing Xcel Energy substation, the interconnection must conform, at a minimum, to the original designed configuration of the substation. Generally, Xcel Energy will not allow a Ring Bus of greater than six breakers. Adding a seventh breaker will require conversion of the station into a Breaker-and-half Bus design. Xcel Energy, at its sole discretion, may consider different configurations due to physical limitations at the site.

Xcel Energy uses transmission line switches to isolate portions of the transmission system for repairs or system operations. Xcel Energy uses a variety of switch types and configurations to ensure safe and efficient system operations and maintenance. Xcel Energy Transmission’s preference is not to install line mounted switches above 115 kV. Where possible, switching functions should take place inside substations. Xcel Energy, at its sole discretion, may consider different configurations due to physical limitations at the site.

Xcel Energy uses a standard three phase connection operated normally closed at sixty-Hertz when tapping an existing transmission line.

Typical interconnection configuration diagrams can be found in **APPENDIX A**. The figures represent generic installations. Circumstances unique to each installation may cause the final configurations to differ significantly from the examples shown. In any case, the Facilities Study will determine final configuration of the Interconnecting Facilities.

The Interconnection Facilities configuration will be allowed only if it does not jeopardize the transmission system’s ability to operate reliably and safely during interconnecting facilities trips (except during a local breaker failure backup operation) and maintenance activities.

B. Modeling Information

All Customer’s equipment manufacturers’ data sheets, load forecast data, and electric motor specification sheets must be available for modeling in steady state, transient/voltage stability, short circuit, and relay setting calculation programs. This includes detailed one-line of the transmission facilities on the customer’s side of the Point of Interconnection and models of any associated power conversion or var support equipment and controls. When applicable, the Customer shall provide to Xcel Energy at the time of application for interconnection, the model data for the proposed load and interconnection facilities. If a suitable user model does not exist, the Interconnection Customer shall provide the IEEE standard models for use with dynamic and transient stability simulations of their equipment. The load flow modeling data must be provided in either General Electric’s PSLF or Siemens PSSE format, as instructed by the entity doing the studies. The Interconnection Customer shall provide, upon request, the model data for any proposed generation or power conversion equipment and protective devices for use with a PSCAD program. Any model data not covered by a Non-Disclosure Agreement may be publicly released by Xcel Energy to meet NERC model development requirements, other NERC standards or other regulatory requirements.

Any time there is a new/updated protection and/or control strategy implemented in the facilities, dynamic models, particularly transient models will need to be re-submitted. This is required for Xcel Energy to maintain compliance with all applicable NERC Reliability standards
https://www.nerc.com/comm/RSTC_Reliability_Guidelines/White_Paper_Odessa_Disturbance_Follow-Up.pdf
The Customer will annually forecast and provide to Xcel Energy the firm MW and MVAR usage on each interconnection. The studies performed will be annual forecasts for summer and winter peak for a period of not less than five years. Forecasts of longer than five years may be required in some operating areas.

Transmission System Guidelines	
 Xcel Energy	Xcel Energy Operating Companies
Interconnection Guidelines for Transmission Interconnected Customer Loads	Version: 13.0
<i>File Name:</i> XEL-POL-TransmissionInterconnectedCustLoads Version 13 - FINAL (10-2-23).docx	Page 14 of 49

C. Separate Systems

A separate system is defined as one in which there is no possibility of connecting the generation on a Customer's system in parallel with Xcel Energy's System. This can be accomplished by either an electrically or a mechanically interlocked switching arrangement which prevents the two power sources (Xcel Energy's and the Customer's) from serving a power load simultaneously. If a Customer has a separate system, Xcel Energy will require verification that the system meets the non-parallel requirements. This will be accomplished by the approval of drawings by Xcel Energy in writing and, if Xcel Energy so elects, by field inspection of the transfer scheme. Xcel Energy requires that the final design prints be sealed by a Professional Engineer (**P.E.**) with a brief description of the non-paralleling scheme documented on the prints.

D. Parallel Operation Of Generation

A parallel system or parallel generation is defined as one in which the generation connected to a Customer's facilities can be connected to Xcel Energy's System. A transfer of power between the two systems is a direct and, at times, a desired result. However, in all cases, all Customer-connected generation sources shall be disconnected from the Xcel Energy system in the event of the interruption of all sources of supply from the Xcel Energy system. The method of disconnection to be used and the required characteristics of the control system used for disconnection will be determined at the time of the Facilities Study.

E. Protective Devices

The Customer is responsible for the overall safe and effective operation of their facilities. Certain protective devices (relays, circuit breakers, etc.) that are specified by Xcel Energy must be installed at the location where a Customer desires to operate interconnected with the Xcel Energy System. The purpose of these devices is to promptly disconnect a Customer's equipment from Xcel Energy's System whenever faults or abnormal operating conditions occur.

Xcel Energy will not be responsible for primary protection of equipment in the Customer's substation. Protective devices (e.g. fuses, relays, circuit breakers, circuit switchers) must be installed by the Customer to the full extent required by all applicable standards to disconnect the Customer's equipment from the Xcel Energy System whenever a fault or abnormality occurs. Such equipment must coordinate with existing Xcel Energy equipment and provide comparable levels of protection as practiced on Xcel Energy's System. In some applications the use of breaker failure protection may be required. The protective devices differ with the size of the installation. The specific requirements will be determined in the Facilities Study. Major factors generally determining the type of protective devices required include:

1. The type and size of the Customer's equipment.
2. The location and system voltage level of the Customer's connection to Xcel Energy's System.
3. Whether generation is connected to the Customer's facilities.

However, this Guideline does not address all of the nuances and complexities involved in designing a protection scheme or for integrating substation facilities into an interconnected electric transmission system. The Customer is responsible for designing their own protection scheme and should consult an expert in the field of system protection.

Specific protective device requirements are described in Section III below.

Transmission System Guidelines	
 Xcel Energy	Xcel Energy Operating Companies
Interconnection Guidelines for Transmission Interconnected Customer Loads	Version: 13.0
File Name: XEL-POL-TransmissionInterconnectedCustLoads Version 13 - FINAL (10-2-23).docx	Page 15 of 49

F. Interference

Operation of the Customer facilities must not cause unusual fluctuation, disturbance, or interference on the Xcel Energy System, or other loads or generators connected to the Xcel Energy System. If such fluctuations or disturbances occur, the Customer will be required to install suitable apparatus to reasonably correct or limit such fluctuation, disturbance, or interference at no expense to Xcel Energy or Xcel Energy's other customers or producers.

G. Voltage, Harmonics, and Flicker

The interconnection of a Customer's equipment with Xcel Energy's System shall not cause any reduction in the quality of service on the Xcel Energy System. No abnormal voltages, frequencies, or interruptions will be permitted. If high-voltage or low-voltage complaints, transient voltage complaints, and/or harmonic (voltage distortion) complaints result from the operation of a Customer's system, Customer's such system may be disconnected from Xcel Energy's System until the Customer resolves the problem. The Customer is responsible for the expense of keeping his equipment in good working order so that the voltage, harmonics, and power factor (PF) requirements are always met.

Control systems for any energy conversion equipment(s) employed shall be designed to preclude excitation of the sub-synchronous modes of oscillation of existing turbine-generators, during either steady-state or dynamic conditions, including converter restart attempts or repeated commutation failures. Similarly, excitation of existing or new power system resonances (whether sub- or super-synchronous) due to non-fundamental current injection shall be effectively prevented.

1. Steady State Voltage Range

The Customer should expect a normal transmission operating voltage range of +/- 5% from nominal. The Customer should contact Xcel Energy to determine the normal operating voltage at their point of interconnection. During system contingency or emergency operation, operating voltages may vary up to +/- 10% from nominal, depending on the planning criteria for PSCo, NSP, and SPS. Each operating company's planning criteria should be consulted for further information. If Interconnection Customer equipment cannot operate within the above range, the Interconnection Customer will need to provide regulation equipment on their system.

2. Dynamic Voltage Range

a. MRO Region

The NSP transmission system is designed to avoid dynamic voltage dips below 0.7 pu voltage due to external faults or other disturbance initiators to meet MRO requirements. Dynamic Voltage Excursions within this range can be expected. Customers are encouraged to design their systems to avoid dropout of control contactors associated with any essential loads during dynamic-power system voltage-swings to levels as low as 0.7 pu. If contactor dropout does occur, and this causes a further voltage excursion, the Customer is required to resolve this problem in a timely manner.

The low-voltage-withstand capability of Customer's equipment should be able to tolerate a duration of 0.5 seconds at 0.7 pu and a total time of 2.0 seconds per occurrence during which the voltage is below

Transmission System Guidelines



Xcel Energy Operating Companies

Interconnection Guidelines for Transmission Interconnected Customer Loads

Version: 13.0

File Name: XEL-POL-TransmissionInterconnectedCustLoads Version 13 - FINAL (10-2-23).docx

Page 16 of 49

0.9 pu. Due to power system dynamic-response characteristics, such dynamic under-voltage occurrences may be experienced repetitively in a back-to-back manner. High-voltage swings of up 1.2 pu are also possible.

b. WECC Region

WECC criteria TPL-001-WECC-CRT-3 WR1.2-WR1.6 state the dynamic voltage requirements for applicable BES buses. The addition of any new load cannot produce system performance that is out of compliance with the values stated above.

c. SPP Region

SPP does not have any dynamic voltage performance criteria. The requirements for each interconnection will be assessed on a case-by-case and location specific evaluation by SPP under Part V to the SPP OATT. SPP is currently reviewing the addition of dynamic voltage performance criteria. New rules if adopted, will apply.

3. Voltage Fluctuations and Other Voltage Variations

Customer loads are not allowed to produce voltage fluctuations, as defined and discussed in IEEE 519 and IEEE 1453, that adversely impact adjacent customers and producers or that exceeds the following limits:

Fluctuations Per Hour	Maximum Allowable Voltage Fluctuation
Less than 2	3.0%
Between 2 to 10	2.0%
Between 10 to 100	1.0%
More than 100	0.5%

In some cases, for Customer loads producing fewer than two (2) fluctuations per hour and depending on the proximity of sensitive loads, it may be necessary to restrict the maximum allowable voltage fluctuation to no more than 2%. The Customer will be responsible for corrections if their facility is the cause of objectionable voltage fluctuations. In addition, where starting or energizing Customer load or equipment will have an adverse impact on Xcel Energy's System voltage, corrective measures may be required on the part of the Customer to limit the voltage changes.

4. Harmonics

The Customer shall not be allowed to introduce, excessive distortion to the Xcel Energy System's voltage and current waveforms per the most current revision of IEEE Standard 519. The harmonic distortion measurements shall be made at the point of common connection (**PCC**) between the Customer and the Xcel Energy System. Xcel Energy advises the Customer to account for harmonics during the early stages of planning and design. Xcel Energy may, at its option, request a harmonic study of the Customer's system near the intended POI prior to and/or after interconnection.

F. Frequency and Frequency Control

Transmission System Guidelines	
 Xcel Energy	Xcel Energy Operating Companies
Interconnection Guidelines for Transmission Interconnected Customer Loads	Version: 13.0
<i>File Name:</i> XEL-POL-TransmissionInterconnectedCustLoads Version 13 - FINAL (10-2-23).docx	Page 17 of 49

All interconnections must comply with the most recent version of NERC Standard PRC-024. Xcel Energy’s phase rotation is ABC counterclockwise in most areas. The Interconnection Party should verify rotation with Xcel Energy before purchasing any equipment.

H. Emergency Load Shed Obligation

In order to meet NERC and Reliability Region standards, Xcel Energy is expected to provide emergency load shed capability. All Customers interconnecting to the Xcel Energy transmission system are expected to install equipment that will give it the capability of participating in the under-frequency, under-voltage, and manual load shedding programs described below. This obligation is based on a Customer’s total end use load operating on the Xcel Energy System within each Reliability Region. As the Customer’s end use load grows, it must continue to demonstrate compliance with this requirement. The Customer can expect periodic Audits by the Regional Reliability Organization for compliance with these requirements.

If the Customer has multiple points of interconnection within a Reliability Region, this obligation may be spread among the various end use loads as the Customer chooses, subject to approval by Xcel Energy. Xcel Energy will validate that the chosen locations will provide sufficient security protection. However, the Customer must demonstrate to Xcel Energy’s satisfaction that the Customer has sufficient load shed capability to meet the NERC and Reliability Region requirements.

While under-frequency and under-voltage load shedding occur automatically due to the action of appropriate relays, manual load shedding is performed under the direction of the Balancing Area Operator. Under all three load-shed conditions, Customer load is not to be restored except under the direction of the Balancing Area Operator.

The Customer is obligated to participate in these load-shed programs and may be required to participate at the discretion of Xcel Energy.

THE DEFAULT LOAD SHEDDING TRIPPING IS 60 CYCLES UNLESS SPECIFIED BY XCEL ENERGY. XCEL ENERGY WILL PERFORM THE NECESSARY STUDIES TO SPECIFY THE MINIMUM LOAD SHED TRIPPING TIME TO COORDINATE WITH GENERATOR PROTECTION SYSTEMS.

1. MRO Region load shed obligations

To comply with NERC and MRO Reliability Region reliability standards, the Xcel Energy is obligated to provide emergency load shed capability as follows:

- a) Frequency-Based Automatic Load Shed
 - at 59.3 Hz, 10% of the load in 60 cycles or less
 - at 59.0 Hz, 10% of the load in 60 cycles or less
 - at 58.7 HZ, 10% of the load in 60 cycles or less
- b) Voltage-Based Automatic Load Shed
 - 10% of the load in 60 cycles or less (may be the same 10% used to meet under-frequency criteria).
- c) Manual Load Shed
 - 10% of the load, but shall not be the same 10% used to meet the under-frequency or under-voltage load shedding criteria

Interconnection Guidelines for Transmission Interconnected Customer Loads

Version: 13.0

File Name: XEL-POL-TransmissionInterconnectedCustLoads Version 13 - FINAL (10-2-23).docx

Page 18 of 49

2. SPP Region load shed obligations

To comply with NERC and SPP Reliability Region reliability standards, the Xcel Energy is obligated to provide emergency load shed capability as follows:

- a) Frequency-Based Automatic Load Shed
 - at 59.3 Hz, 10% of the load in 60 cycles or less
 - at 59.0 Hz, 10% of the load in 60 cycles or less
 - at 58.7 HZ, 10% of the load in 60 cycles or less
- b) Voltage-Based Automatic Load Shed
 - SPS does not have an undervoltage load shed program at this time.
- c) Manual Load Shed
 - 10% of the load, but shall not be the same 10% used to meet the under-frequency or under-voltage load shedding criteria

3. WECC Region load shed obligations

To comply with NERC and WECC Reliability Region reliability standards, Xcel Energy is obligated to provide emergency load shed capability as follows:

- a) Frequency-Based Automatic Load Shed
 - at 59.1 Hz, 5.3% of the load in 14 cycles or less
 - at 58.9 Hz, 5.9% of the load in 14 cycles or less
 - at 58.7 HZ, 6.5% of the load in 14 cycles or less
 - at 58.5 HZ, 6.7% of the load in 14 cycles or less
 - at 58.3 HZ, 6.7% of the load in 14 cycles or less
 - at 59.3 HZ, 2.3% of the load in 15 seconds or less
 - at 59.5 HZ, 1.7% of the load in 30 seconds or less
 - at 59.5 HZ, 2.0% of the load in 1 minute or less
- b) Voltage-Based Automatic Load Shed
 - Approximately 10% of the load in 60 cycles or less (may be the same 10% used to meet under-frequency criteria)
- c) Manual Load Shed
 - 10% of the load, but shall not be the same 10% used to meet the under-frequency or under-voltage load shedding criteria

I. Minimum Power Factor Requirements

New Points of Interconnection (POI), transformer additions, and planned transformer capacity upgrades are expected to provide their own power factor correction. Requirements are stipulated by load size, in recognition of the complexities of finely controlling power factor for smaller loads. For the purposes of the categorization below, multiple PoIs at the same location will be aggregated.

Transmission System Guidelines



Xcel Energy Operating Companies

Interconnection Guidelines for Transmission Interconnected Customer Loads

Version: 13.0

File Name: XEL-POL-TransmissionInterconnectedCustLoads Version 13 - FINAL (10-2-23).docx

Page 19 of 49

1. For PoIs with peak hourly loads less than 1 MW, Xcel Energy recommends the Customer controls the power factor to minimize losses and reactive power factor impacts on the Transmission System.
2. For PoIs with an annual peak hourly load during the past 24 months greater than 1 MW, the Customer will control the power factor between 95% lagging and leading at the POI when the Customer's load at the POI is greater than 85% of maximum load. Power factor is not to exceed 95% leading when the Customer's load at the POI is below 50% of maximum load.
3. Over time, it is the intention of the Transmission Provider and the Interconnection Customer to improve the power factor requirement between 98% lagging or leading for the POIs with annual peak hourly loads greater than 5 MWs, unless those loads are already meeting the 98% power factor requirement in which case the power factor level should be maintained. The Interconnection Customer will control the power factor between 98% lagging and 98% leading when the Interconnection Customer's load at the POI is greater than 85% of maximum load. Power Factor is not to exceed 98% leading when the load at the POI is below 50% of maximum load.

With mutual written agreement, reactive power support may be considered at an adjacent substation provided the substations are in electrically close proximity.

If during normal operation (system intact or under transmission contingency conditions) the voltage in a portion of the transmission system deviates from the range described in Section II.G.1, Xcel Energy will survey these interconnected substations which, in its opinion, may contribute to the voltage concern and require the Customer to demonstrate either by transmission side metering or low side metering corrected for transformer reactive power consumption that the Customer meets the intended level of power factor correction. Compliance in meeting the power factor requirement will reasonably exclude Customer's emergency conditions, during Customer switching of facilities, and periods when transformer loading and required pf correction would result in transformer resonance conditions. Any unacceptable deviations are to be corrected in a timely manner.

Some portions of the power system are in or adjacent to areas where other power suppliers (Municipals or Co-ops) utilize "ripple" load management systems. These systems employ an on-off keyed carrier signal (typically in the range of 150-400 Hz) injected into the power systems to address Customer site load management devices. Installation of shunt capacitor banks may cause degradation of the ripple signal strength due to shunting to ground of the ripple signal through the capacitor bank(s). To prevent such degradation, appropriate tuned blocking filters may be required.

J. Fault Current

Xcel Energy's protective equipment fault current capability is based on the use of equipment with greater capability than the maximum fault current available at a location. The Customer's equipment capability must exceed the maximum fault current available. The exact value of available fault current depends upon location and circuit configuration and will be determined in the Interconnection Facilities studies. The Customer must work closely with Xcel Energy at the time of the interconnection design to determine the available fault current at the specific location of interconnection. In addition this value may increase over time due to growth and changes in the interconnected power system. Therefore, the Customer should make accommodations for reasonable increases in fault current in designing its Facility.

K. Disconnect Device/Point of Demarcation

1. Point of Demarcation

Transmission System Guidelines



Xcel Energy Operating Companies

Interconnection Guidelines for Transmission Interconnected Customer Loads

Version: 13.0

File Name: XEL-POL-TransmissionInterconnectedCustLoads Version 13 - FINAL (10-2-23).docx

Page 20 of 49

The agreement and the interconnection specific exhibits shall clearly indicate a point of electric conductor demarcation or point of ownership change.

The electric demarcation point may be at the connection terminals of an electrical disconnect switch or at another separable connection, such as a splice, bus bar joint or bolted jumper connection. Demarcation points at the mid span of conductors should be avoided except in special situations such as when crossing state lines and other jurisdictional boundaries. The intent of these demarcation recommendations is to minimize the need for Xcel Energy personnel to enter a customer facility to perform work and to eliminate the need for customer personnel to enter an Xcel facility to perform work.

For overhead transmission line connections outside of substations, the preferred demarcation point is at a bolted jumper connection to the dead-end hardware of the customer's line.

For overhead connections that leave Xcel substations, the preferred demarcation point is on a dead-end structure one or more spans outside the Xcel substation.

For back-to-back substations, connections within a substation, and single span connections the demarcation point may be at a joint in the bus work connecting the stations or at the customer end of the connecting span.

Fiber, other communication circuits, and control systems shall have demarcation points clearly indicated in the agreement and interconnection specific exhibits. The communication demarcation points are typically splice locations and may be different from the electrical demarcation point.

2. Disconnecting means

One or more disconnect switches must be installed on the customer side of the connection to isolate the customer's utilization facilities from the Xcel Energy system.

The disconnect must provide a visible air gap. Circuit breakers, circuit switchers and similar devices must be supplemented by a switch with a visible air gap.

The disconnect must be between the Xcel Energy system and all customer equipment except overhead and underground conductors and bus work.

The disconnect shall be designed to either break the full load current of the connection or to be operated in coordination with circuit breakers and other load interrupting devices. In a coordinated design, the disconnect switch may be required to break a line or transformer charging current. The disconnect switch shall open all three phases simultaneously.

The switching scheme and associated protection system design shall be developed in coordination with Xcel Energy system operations and described in the interconnection agreement.

3. Access

The disconnecting device must be accessible to Xcel Energy personnel. The Customer must provide access to the disconnect switch at all times of the day and night and on short notice. (24-hour telephone

Transmission System Guidelines	
 Xcel Energy	Xcel Energy Operating Companies
Interconnection Guidelines for Transmission Interconnected Customer Loads	Version: 13.0
<i>File Name:</i> XEL-POL-TransmissionInterconnectedCustLoads Version 13 - FINAL (10-2-23).docx	Page 21 of 49

number, guard desk information, etc.). The disconnecting device should be capable of being padlocked in the open position with a standard Xcel Energy padlock. The Customer shall not remove any Xcel Energy locks or safety tags applied to the disconnecting device. The disconnecting equipment must be clearly labeled.

L. Effective Grounding

Xcel Energy maintains effective grounding on its transmission systems, as defined by IEEE 142. All Customer facilities connected to Xcel Energy’s System must be effectively grounded per the IEEE 142 requirement. These calculations should be made as if the Xcel Energy system was disconnected from the Customer (The Customer must meet the effective grounded system criterion independent of the Xcel Energy system).

IEEE 142 requires that: The positive sequence reactance is greater than the zero-sequence resistance ($X_1 > R_0$); and the zero-sequence reactance is less than three times the positive sequence reactance ($X_0 < 3X_1$).

III. EQUIPMENT, PROTECTION AND CONTROL REQUIREMENTS

This section indicates the minimum Xcel Energy design requirements for the major components of the Customer’s facilities interconnecting to the Xcel Energy transmission system. Any facilities constructed by the interconnection customer that will be ultimately owned by Xcel Energy shall be designed using Xcel Energy substation and transmission design criteria and material standards, which will be made available upon request. The interconnecting party must communicate and coordinate its system equipment, and protection and control designs and settings with the Xcel Energy engineering staff.

A. Fault Clearing

1. A circuit breaker is normally required to be installed at the PoI. Circuit breakers must be capable of interrupting present and future available fault current at the location at which they are being installed. Fault currents will change on the Xcel Energy system over time. The Interconnection Customer needs to periodically check fault levels to ensure their breaker meets these ever-changing values. This device will be installed and owned by the Interconnection Customer.
2. The Customer will provide and maintain in operable condition equipment and systems capable of interrupting maximum fault levels within the Customer’s transformers, distribution busses and feeders.
3. Application of ground-switches to trigger remote tripping is not an acceptable practice.
4. The Customer’s equipment must not trip existing transmission lines as a primary protection method.
5. The Customer must immediately and automatically isolate any faulted or failed equipment from the Xcel Energy System. This automatic equipment must be compatible with the existing transmission protection equipment.

Xcel Energy will require approval only for those portions of the Customer’s design that pertain directly to the protection of Xcel Energy System. Xcel Energy may make suggestions or comment on other areas; however, the Customer is responsible for the design of protection schemes associated with their facility.

B. Utility Grade Relays

Transmission System Guidelines



Xcel Energy Operating Companies

Interconnection Guidelines for Transmission Interconnected Customer Loads

Version: 13.0

File Name: XEL-POL-TransmissionInterconnectedCustLoads Version 13 - FINAL (10-2-23).docx

Page 22 of 49

Utility grade protective and control relays are required for all Customer-owned facilities interconnected to the Xcel Energy System. The applicable relays are described in the next section (C. Minimum Protection Requirements) or as designated by the Facilities Study. The relays must:

1. Meet or exceed ANSI/IEEE Standards for protective relays (i.e., C37.90, C37.90.1, C37.90.2 and C37.90.3).
2. Have documentation covering application, testing, maintenance, and service.
3. Give positive indication of what caused a trip (Targets).
4. FT-1 switches are required to facilitate testing.

The Customer is strongly encouraged to use microprocessor-based protective relays. The self-diagnostic abilities, the sequence of events capabilities, and the increased flexibility of application are highly desirable. Xcel Energy may require that microprocessor style relays be utilized for certain interface relay applications.

C. Minimum Protection Requirements

1. The following functions are required as a minimum to protect Xcel Energy's equipment. The Facilities Study will determine specific protective requirements. In all cases good utility practice shall be followed in all relaying and control system designs.
 - a) Line Relaying, if required, will need to be coordinated with and reviewed by Xcel Energy.
 - b) Power Transformer High Voltage Fuses if proper coordination can be achieved, or Power Transformer Differential and/or Overcurrent Relaying.
2. The following additional protection functions may be suggested or required depending upon the size of the load, nature of interconnection, and coordination requirements with the Xcel Energy Protective Systems:
 - a) Breaker Failure Relaying for power transformer high-side interrupting device
 - b) Undervoltage/Underfrequency Load-shed Relaying
 - c) Transfer trip
 - d) Power Quality Meter

D. Redundant/Backup Protection

Relays protecting the Xcel Energy system shall be designed to ensure that the failure of a single protective relay will not result in failure to clear the fault. Failure to trip during fault or abnormal system conditions due to relay or breaker hardware problems or from incorrect relay settings, improper control wiring, etc. is always a possibility. The design shall provide the necessary backup that will meet the Xcel Energy standards and regional protection requirements.

E. Synchronization

If distributed generation is present, the customer shall install the necessary equipment to prevent out of sync closing.

Transmission System Guidelines	
 Xcel Energy	Xcel Energy Operating Companies
Interconnection Guidelines for Transmission Interconnected Customer Loads	Version: 13.0
<i>File Name:</i> XEL-POL-TransmissionInterconnectedCustLoads Version 13 - FINAL (10-2-23).docx	Page 23 of 49

F. Station Power/Station Services

The Customer is responsible for securing a source of AC station power for their Interconnection Facility. If applicable, Xcel Energy may provide the AC station power also pursuant to corresponding regulatory requirements and the Retail Tariff of the local Xcel Energy Operating Company. The Customer shall be responsible for installing the necessary equipment needed to provide its own station power. The Customer may also be required to provide AC and/or DC control power upon request.

G. Grounding System

The Customer is responsible for the appropriate safety grounding of their equipment and facility. At the point of interconnection, the Customer's grounding equipment must be compatible with Xcel Energy's grounding equipment. The Customer shall submit the grounding system study and design for Xcel Energy review prior to construction. The ground grid design must comply with IEEE 80 and properly address site extremes. Site tests should be completed to determine soil resistivity prior to ground grid design. Interconnections, if any, between Xcel Energy and Customer grounding systems must protect from damage all copper control, relaying, and/or communication circuits passing between the facilities under all operating conditions.

H. Control, Protection, and Communication Interconnections

The design and installation of all copper, fiber, and other signals, if any, passing between adjacent Xcel Energy and Customer facilities shall be coordinated with Xcel Energy. A point of demarcation shall be identified for raceway, cabling, and other interfaces for the delineation of the scope of responsibility between the parties.

I. Communication Channel (s)

Xcel Energy may require that a communication channel and associated communication equipment be installed as part of the protective scheme. This channel may consist of power line carrier, fiber optic cable, radio, or other means. Communication channels may be needed for telemetry, load-shed control, monitoring, or protection/control purposes. The Facilities Study will determine the specific communication channel requirements.

J. Metering and Telemetry

All Customers are required to have metering installed such that the delivery of power to the Customer from the Xcel Energy System can be determined. The metering installation shall be of billing accuracy. The meter installation will typically be located at the low side of the Customer's transformer with the revenue meter compensated to measure at the PoI. A few connections may have conditions requiring a different location and will be evaluated on a site-specific basis. The metering installation will typically be owned and maintained by Xcel Energy. The metering installation includes the CTs, VTs, meter, recorder, remote communication unit (usually a modem), and any auxiliaries required. Xcel Energy may require, in special circumstances, that a readily available power quality meter (a.k.a. power quality monitor) be installed at the PoI. Power quality metering will not require revenue class instrument transformers. Additional detail on revenue class metering and telemetry to the Xcel Energy System Control Center is provided in Appendix B. Metering values (MWs and MVars) for all load interconnections will need to be sent to the Xcel Energy System Control Center via a RTU, Dual-Port RTU, Mini RTU, or a device that can provide this RTU functionality.

Transmission System Guidelines	
 Xcel Energy	Xcel Energy Operating Companies
Interconnection Guidelines for Transmission Interconnected Customer Loads	Version: 13.0
File Name: XEL-POL-TransmissionInterconnectedCustLoads Version 13 - FINAL (10-2-23).docx	Page 24 of 49

K. Supervisory Control and Data Acquisition (SCADA)

Certain Customer substations that have a circuit breaker or circuit interrupter as the first protective device on the Customer side of the POI must provide the Xcel Energy System Control Center the equipment data and statuses, which are to include, but are not limited to:

- a) Transmission breaker or circuit interrupter position.
- b) Motor-operated disconnect position.

L. Voltage and BIL Values

The Customer must ensure that all equipment is adequately protected from excessive system over-voltages. This includes selection of equipment Basic Impulse Insulation Level (BIL) and protective devices (e.g. surge arresters) to achieve proper insulation coordination with Xcel Energy’s system and protection of equipment. The addition of new load to Xcel Energy’s System in general should be modeled, and Transient Network Analysis (TNA) or Electromagnetic Transients Program (EMTP) studies may be required. The Facilities study will identify whether these detailed studies are required. If so, these studies should be completed before other major engineering work on the project commences. The Customer and Xcel Energy will need to determine, through their studies, the appropriate BIL, SA MCOV and energy requirements for their equipment.

M. Interconnection Facility Ratings

Where any of the customer’s facilities are or become integral to a current-carrying path subject to FAC-008:

- The customer’s equipment shall not limit the continuous or emergency ratings of the facility.
- The ratings of the equipment shall be coordinated with Xcel Energy’s facility rating group.
- Plans for replacement or material changes of the equipment shall be coordinated with Xcel Energy’s facility rating group prior to finalizing design.

N. Remedial Action Scheme

The use of a Remedial Action Scheme (formally called a Special Protection System) within the Xcel Energy service territory is addressed in the Transmission Planning Criteria Manual for the applicable operating company. NSPM and NSPW Transmission System. The Transmission Planning Criteria Manual for the NSPM and NSPW Transmission System can be found on MISO’s website [Policy, Procedure, Standards Template \(misoenergy.org\)](http://www.misoenergy.org/PDF/Policy_Procedure_Standards_Template.pdf)

The application of a Remedial Action Scheme (RAS) on the SPS transmission system is permitted only if the RAS is temporary. The Southwest Power Pool (SPP) Planning Criteria identifies the requirements for a Temporary RAS installation along with the RAS Sponsor’s NERC compliance obligations associated with the Temporary RAS. The addition of an Extended Use RAS is not permitted on the SPS transmission system. The [SPP Planning Criteria](http://www.spp.org/spp-documents-filings/?id=18162) document can be found on the SPP website www.spp.org (<https://www.spp.org/spp-documents-filings/?id=18162>).

IV. LOAD INTERCONNECTION PROCESS

A. Transmission Service Request

Transmission System Guidelines	
 Xcel Energy	Xcel Energy Operating Companies
Interconnection Guidelines for Transmission Interconnected Customer Loads	Version: 13.0
File Name: XEL-POL-TransmissionInterconnectedCustLoads Version 13 - FINAL (10-2-23).docx	Page 25 of 49

Note: As determined by FERC, a request for interconnection of a substation **does not** constitute a request for transmission service. The process described herein is not sufficient, nor intended to determine the capability of the transmission network to supply the electric load power and energy requirements. In addition, a signed Load Interconnection Agreement does not provide the interconnection customer with any rights to transmission service.

A customer desiring transmission service from Xcel Energy or the appropriate ISO must follow the procedures of the Xcel Energy Joint OATT or the ISO OATT in requesting transmission service.

B. Transmission Load Interconnection Requests Steps

1. Complete the "Transmission to Transmission and Transmission to Load Interconnection Request" form. Forms in electronic format may be obtained from the contacts below. Specify the location of the requested interconnection (county, town and street or section, township, and range), a 10-year demand forecast (MW and MVAR), the number of transformers and their proposed nameplate capacity in mega volt-amperes (MVA), and the proposed in-service date. Any reductions in load at other interconnection or delivery points due to the addition of this new interconnection point or modification to an existing point should also be specified. (The ultimate point of interconnection and voltage level will be determined based on the applicant's study review or the Xcel Energy interconnection study) In addition the requesting party must supply their proposed equipment ratings as required by Xcel Energy to allow the establishment of the facility rating for the interconnecting facilities or as required to allow appropriate system simulation modeling of the interconnecting facility. Final required facility ratings will be agreed to based on the results of the interconnection study.
2. Return completed "Transmission to Transmission and Transmission to Load Interconnection Request" and single line diagram to the appropriate Xcel Energy representative as listed below:

If the proposed facility is RETAIL load anywhere in Xcel Energy Service territory.

Retail Transmission load interconnection requests are taken through the [Xcel Energy Sales Account Representatives](#); send completed application and other required information to the appropriate Account Representative. If you are unsure who your Account Representative is, contact the Business Solutions Center and they can help you identify your Representative. Xcel Energy Business Solutions Center 1-800-481-4700

If the proposed WHOLESALE load serving facility to be interconnected to the Xcel Energy transmission system.

This location currently takes load interconnection requests through the Transmission Business Relations Department; send completed application and other required information to Xcel Energy: Current contact information for the three areas (NSP- Minneapolis, PSCO – Denver, SPS – Amarillo) can be found on the Xcel Energy website (xcelenergy.com > Safety & Operation > Transmission > About Transmission > Interconnections for Transmission). Specific contact information can be found on the Xcel Energy website:

Note: The Midcontinent Independent System Operator (MISO) assumes responsibility for this activity on the NSP-MN-WI transmission system.

Interconnection Guidelines for Transmission Interconnected Customer Loads

Version: 13.0

File Name: XEL-POL-TransmissionInterconnectedCustLoads Version 13 - FINAL (10-2-23).docx

Page 26 of 49

Note: Sometime in the future the Southwest Power Pool (SPP) will be assuming responsibility for this activity on the SPS transmission system.

3. Xcel Energy will review the Interconnection request for completeness and evaluate the need for studies. Study cost estimates, depending on the complexity of the request or workload, are generally available along with a study agreement within 30 calendar days of the receipt of the interconnection request. The cost of studies will be borne by the Party requesting the interconnection, with 50 % of the estimated study cost due when the study agreement is executed. The remainder of the actual cost will be billed following completion of the study.
4. Studies to be completed by Xcel Energy at Customer expense:

a. System Impact Study

The System Impact Study, if required, will determine if the transmission system has adequate load serving capability and will determine the major components required to interconnect with the Xcel Energy Transmission System. The System Impact Study may include: power flow analysis, fault study, stability study (if required), transient switching analysis, and impact to other Customers on the Xcel Energy Transmission System. System Impact Studies will take an estimated 6 – 8 weeks to complete. During the analysis, additional details of the proposed facility may be required and will be requested from the Customer as necessary.

Following receipt of the completed study, the party requesting interconnection will have 15 business days to decide whether to proceed. A decision to proceed may lead to additional studies or directly to the negotiations for an Interconnection Agreement. The Customer confirms their decision to proceed by submitting a letter to that effect.

b. Facilities Study

The Facilities Study (if required) will determine the detailed engineering design and final requirements for the interconnection to proceed and costs based upon the equipment configuration determined by the Customer and Xcel Energy. The Facilities Study report will provide the following information:

- Interconnection facility cost estimate.
- System upgrade requirements for interconnection only, not transmission service related.

Xcel Energy and the applicant will enter into a "Facilities Study Agreement" to perform the required detailed engineering. The scope of the study will be detailed in the agreement. Xcel Energy will charge the applicant for all costs associated with the Facilities Study. Xcel Energy's analysis will be limited to the requirement to protect Xcel Energy's equipment, personnel, and customers from adverse impacts due to the applicant's Interconnection.

The applicant shall provide all requested items as soon as practical to facilitate completion of necessary studies and agreements. After Xcel Energy has received all of the required information, the Facilities Study will take an estimated 6 to 8 weeks to complete. Depending upon the complexity of the installation, and other projects in the queue, the study time may be extended. To establish installation details, meetings will usually be held with the Xcel Energy representative, the applicant, the applicant's consulting engineer, the contractor, and the equipment manufacturer.

**Interconnection Guidelines for Transmission
Interconnected Customer Loads**

Version: 13.0

File Name: XEL-POL-TransmissionInterconnectedCustLoads Version 13 - FINAL (10-2-23).docx

Page 27 of 49

The facilities study may include, but not limited to fault study, stability study, harmonic analysis, minimum protection requirements, and impacts to other customers on the Xcel Energy system. The facilities study does not include studies for MAPP TPSC and DRS acceptance or final engineering, construction, equipment purchase and/or delivery details.

Following receipt of the completed study, the party requesting interconnection will have 15 business days to decide whether to proceed. A decision to proceed may lead to additional studies or directly to the negotiations for an Interconnection Agreement after the applicant confirms their decision to proceed by submitting a letter to that effect.

c. Combined System Impact Study/Facilities Study

After reviewing the request, Xcel Energy may suggest that a combined System Impact/Facilities Study be completed. The scope of the combined study will be a combination of the individual study scopes as defined above. If a combination study is deemed appropriate, there will be no decision point between the System Impact and Facilities Study stages. The conclusions of the combined study will be the same as if each study had been conducted independently. This combined study is useful when the upgrades required for interconnection are limited and can be well defined early in the study process. If the upgrades for interconnection are complex, separate studies are recommended. Unless deemed by Xcel Energy to be particularly complex, the combined study process will not exceed the sum of the two study estimate times above.

Following receipt of the completed study, the party requesting interconnection will have 15 business days to decide whether to proceed. A decision to proceed will lead directly to the negotiations for an Interconnection Agreement after the applicant confirms their decision to proceed by submitting a letter to that effect.

5. Execute / Amend a Load Interconnection Agreement

Normally, before Xcel Energy initiates procurement, construction or installation of any facilities related to the interconnection of the applicant's substation facilities to the system, an Interconnection Agreement must be executed between Xcel Energy and the applicant. In some cases, an Engineering and Procurement Agreement (E&P) may be executed that will allow Xcel Energy to begin any engineering or material procurement during the negotiation of the Interconnection Agreement if an expedited schedule is required. The Interconnection Agreement will define the terms and conditions under which Xcel Energy will construct the facilities to interconnect the new substation and, in some cases, will upgrade portions of the transmission system. The Interconnection Agreement will also allocate the costs of the interconnection facilities and system upgrades between the applicant and Xcel Energy. The Interconnection Agreement will also prescribe the design requirements for interconnection of the applicant's substation facility. Once the Interconnection Agreement is executed, Xcel Energy will proceed with the interconnection process and the Interconnection will be filed with the applicable regulatory agency.

The fully executed Interconnection Agreement shall control with respect to any issue in conflict with the specifications of these Load Interconnection Guidelines.

6. Notification of new and modified facilities to others is addressed:

Transmission System Guidelines



Xcel Energy Operating Companies

Interconnection Guidelines for Transmission Interconnected Customer Loads

Version: 13.0

File Name: XEL-POL-TransmissionInterconnectedCustLoads Version 13 - FINAL (10-2-23).docx

Page 28 of 49

- a) For NSP primarily through the MISO model building process (MISO Transmission Expansion Plan - MTEP) process. After the interconnection is agreed to, if the two parties are MISO-Data Representative, they report their own facilities changes and model data to MISO in the MISO Model Building process. If the interconnecting party is not an MRO –DATA Representative, NSP will report and model their facilities. The process is similar for the MISO annual MTEP process.
- b) For PSCo notification of new and modified facilities is accomplished through the Colorado Coordinated Planning Group (CCPG) reporting process. Xcel Energy notifies the CCPG member utilities of existing, new or planned projects and provides status reports to CCPG member utilities. CCPG is a joint, high voltage transmission system planning group that assures reliability in the planning, development and operation of the high voltage transmission system in the Rocky Mountain Region. CCPG completes reliability assessments, develops joint business opportunities, and accomplishes coordinated planning using a “single system” planning concept that considers the Colorado utilities as one transmission entity for the purpose of meeting the transmission needs of the Colorado utilities in the most cost-effective way.
- c) For SPS primarily through the SPP model building process and the SPP OATT Attachment AQ Delivery Point Addition Process. SPS will report any changes through the model building process and the interconnecting party will either report through that process, the annual SPP OATT delivery point forecast update, or report the delivery point addition to SPP directly. For additions that are not subject to the SPP OATT Attachment AQ, SPS will report those changes through the SPP model building process and the interconnecting party will also report the addition to SPP for confirmation and compliance purposes.

V. ACCEPTANCE TESTING AND INSPECTION REQUIREMENTS

Xcel Energy requires all Customers proposing to interconnect to the Xcel Energy System be in compliance with the applicable testing and/or performance requirements.

A. General

Prior to the actual energization of the interconnecting equipment with the Xcel Energy System, all pertinent contracts must be signed and all equipment modifications must be complete. Customers are required to demonstrate the correct operation of all interface protective and control devices to Xcel Energy. Xcel Energy shall define and witness but is not responsible for performing this demonstration.

The Customer must provide detailed information on the protective relaying, metering, and control (including sync-check) equipment that will interface with the Xcel Energy System. This is usually provided on a relaying and metering one-line (and possibly a three-line) diagram. Basic proposed AC and DC schematics or specification of logic may also be provided at this time. This information is required 90 days before the interconnection equipment in-service date, along with a listing of the specific relays, etc., including information on the manufacturer, model number, relay ranges, etc. Xcel Energy requires at least two sets of any design documentation packages sent. If any subsequent changes are made, the Customer shall provide Xcel Energy a set of revised one-lines, schematics, construction drawings, dynamic/transient models, etc. Based on this information, Xcel Energy will develop and deliver to the Customer the required demonstration test details within 30 days after receipt of information from Customer. A coordination meeting shall be held with Xcel Energy and the Customer to clarify any questions that may exist before testing begins. The Customer is also required to hold a coordination meeting with the Xcel Energy Transmission Control Center to establish a specific switching sequence for the initial energizing of the Interconnection Facilities. The switching procedure will include a sign-off provision for the Customer.

Transmission System Guidelines	
 Xcel Energy	Xcel Energy Operating Companies
Interconnection Guidelines for Transmission Interconnected Customer Loads	Version: 13.0
<i>File Name:</i> XEL-POL-TransmissionInterconnectedCustLoads Version 13 - FINAL (10-2-23).docx	Page 29 of 49

Scheduling of demonstration testing should be coordinated through Xcel Energy with a minimum of three (3) business days notice. All testing shall be completed at least 7 days prior to the planned in-service date to provide time to resolve problems identified during testing. If no problems are identified then the equipment can be placed in service without delay. Based on the location and type of interconnection, Xcel Energy may, at Xcel Energy's sole discretion, require only a design and relay settings review and not require a site visit. Customers shall be responsible for determining their own relay settings. At least 90 days before startup testing, the Customer must supply the proposed settings for the relays, including support documentation (e.g. PRC-027/PRC-025 documentations, calculations, fault studies, time over-current relay coordination curves, etc.) for approval by Xcel Energy.

The Customer shall supply certified test reports for Xcel Energy's required protective relaying, interlocks, and any equipment directly connected to Xcel Energy's System (Customer's transformers and/or breakers). Certified test reports shall be sealed by a registered Professional Engineer (P.E.). Xcel Energy's personnel may require witnessing some or all of the tests, calibrations, and the relay setting applications. The final "as-built" documentation for the interconnection facilities, including all drawings and final "as left" relay settings, must be provided by the Customer to Xcel Energy no later than 90 days after commercial operation commences.

Xcel Energy document TCS-4 "Testing Criteria" provides the specific criteria that Xcel Energy uses for ensuring its electrical equipment is properly tested and checked out. Xcel Energy requires that the Customer's facilities that are an integral part of the Xcel Energy System or may disrupt the Xcel Energy system due to miss-operation or failure, must undergo a similar level of testing and checkout. The demonstration testing indicated above is employed to ensure that the Customer has completed the appropriate testing and checkout. Specific regional requirements may apply and may be obtained from the regional Xcel Energy representative by request.

The Customer must assign one qualified and proficient protection and controls person to be the main point of contact throughout the commissioning phase of the project. This person should have adequate field experience in protection and control of high-voltage equipment as appropriate to the system they are working on. This person's experience should include, but not limited to polarity checks, phase-outs, relay calibration, and trip testing for multiple large projects. This person will also insure adherence to these Guidelines. The Customer must also provide qualified electricians, technicians, and operators to perform the demonstration testing. The Customer must supply all personal protective equipment and designate any procedures necessary to assure that safety precautions are taken while working near energized equipment.

Inspection and approval by Xcel Energy does not constitute a warranty or relieve the Customer of responsibility for the operating condition or installation of the equipment and may not be relied upon by the Customer for that purpose. Once the facility is interconnected, Xcel Energy will retain the right to inspect the facility if the operation is suspected of causing problems for other Xcel Energy customers and retains the right to inspect the facility of the Customer at Xcel Energy's discretion.

B. Demonstration

The Customer and Xcel Energy shall follow the following steps in assuring that the new facilities have been adequately tested prior to energization.

1. CONSTRUCTION TESTING DOCUMENTATION REVIEW

The Customer must complete field-testing of all their electrical equipment prior to commissioning and energization. This includes physical testing of equipment such as transformers and circuit breakers per the

Transmission System Guidelines



Xcel Energy Operating Companies

Interconnection Guidelines for Transmission Interconnected Customer Loads

Version: 13.0

File Name: XEL-POL-TransmissionInterconnectedCustLoads Version 13 - FINAL (10-2-23).docx

Page 30 of 49

manufacturers' recommendations. This testing also includes setting and testing of relays and control systems per the manufacturers' recommendations, as well as verifying Xcel Energy approved relay settings. The extent of testing shall be consistent with the level of testing specified in the International Electrical Testing Association (NETA) or National Institute for Certification in Engineering Technologies (NICET) and good utility practice. These tests shall be completed prior to demonstration testing as outlined in the following paragraph. Xcel Energy may require being a witness to some of these testing activities. Xcel Energy will notify the Customer prior to the start of testing if witness testing is required. In some cases, review of these test reports shall constitute sufficient demonstration that proper testing has been completed.

The Customer must submit reports for all tests performed for approval by Xcel Energy. All revisions and changes found on field drawings shall be shown on the Customer drawing and copies provided to Xcel Energy for approval by Xcel Energy. A written record must be kept of all tests showing date, personnel performing test, signature or initial of person completing tests, equipment or material tested, as-left results, and type of testing equipment used by manufacturer, model type, and model serial number. The test sheets must show all equipment nameplate data (including for all bushings and surge arresters).

The requirements in this paragraph apply only to equipment that will be owned by Xcel Energy. Two copies of the final test reports must be submitted. Three copies of application software and instruction books are to be supplied to Xcel Energy along with the test reports.

The Customer must download settings and programs from each relay and programmable logic controller after testing to retrieve all as-left-in-service settings, and shall copy these files onto a CD-ROM, or e-mail the data to Xcel Energy. For non-microprocessor-based relays, test sheets or reports for each device are to be completely filled out. All relay setting sheets are to be checked against as-left settings on the corresponding relay device and signed as being complete by the responsible technical person. The CD-ROM, test sheets, reports, and settings are to be labeled with equipment identification numbers, relay type numbers, and relay device numbers and returned to Xcel Energy with the test reports. The address is provided in Section II. of these Guidelines.

2. DEMONSTRATION TESTS

Demonstration tests must be employed to ensure that each of the required protection systems and protective devices operate correctly. These tests are used to verify that the Customer has completed testing as indicated in the preceding paragraph. These tests also verify synchronizing equipment and the proper operation of the Xcel Energy – Customer interface protective relays. Xcel Energy will produce the demonstration test requirements and deliver them to the Customer. Upon performance and certification of the Demonstration, the Customer will be granted approval for energization of their interconnection equipment with Xcel Energy's System. Unsuccessful demonstration may lead to delays in the Customer facility in-service date. Xcel Energy and the Customer will develop an initial energization procedure at least two weeks prior to energization. If deemed necessary by Xcel Energy, a meeting will be held on site within one week of the energization date to discuss any particulars of the initial energization.

The actual demonstration requirements will depend upon the final, approved AC/DC schematics, relay settings, etc. This demonstration is intended to be non-destructive. However, Xcel Energy will not be liable for any equipment damage or injury resulting from the use of these guidelines. It is the responsibility of the Customer to demonstrate the operation of all protective devices in a safe manner and in a manner that does not adversely affect the Customer's equipment or any equipment on the Xcel Energy System. Xcel Energy

Transmission System Guidelines	
 Xcel Energy	Xcel Energy Operating Companies
Interconnection Guidelines for Transmission Interconnected Customer Loads	Version: 13.0
<i>File Name:</i> XEL-POL-TransmissionInterconnectedCustLoads Version 13 - FINAL (10-2-23).docx	Page 31 of 49

recommends that similar tests be performed for the Customer’s other relays to insure the adequacy of all protective relaying.

3. POST IN-SERVICE TESTS

These tests are employed for verification of correct relay connections under actual load conditions. This is commonly known as “load checking”. These checks are completed by directly measuring actual operating quantities in differential, distance, and overcurrent relays. This also includes spot-checking of metering and SCADA systems. Post in-service tests may also include online tests of substation equipment including insulating oil tests of power transformers and infrared-thermography testing.

C. Future Changes In Requirements

From time-to-time new requirements for testing, reporting, equipment and/or performance are established by MRO, SPP, WECC, NERC, etc., for interconnections. The Customer should take steps so it is notified of any changes by the applicable entity. If a Customer fails to comply with these requirements and Xcel Energy is required to pay monetary penalties assessed to Xcel Energy as the balancing area entity responsible for regional interconnected system reliability. Xcel Energy will bill the Customer for any monetary penalty resulting from the non-performance of the Customer.

D. Performance of Tests

The Customer must test all wire, cable, electrical equipment, and systems installed by the Customer to assure proper installation, adjustment, setting, connection, and functioning. The Customer must inform Xcel Energy of any equipment or system that fails testing or that is deficient in any matter. The extent of testing where modifications are made to existing circuits shall be sufficient to check the entire trip/control/CT/VT path as if it were new. Xcel Energy will not be responsible for any damage to equipment or material due to Customer’s inadequate, substandard, improper test procedures or test apparatus handling.

Xcel Energy reserves the option to assign its personnel to assist the Customer in checking out certain control schemes where Xcel Energy concludes such assistance is necessary to meet the project schedule. If Xcel Energy should exercise this option, the Customer will be notified in advance of the extent of Xcel Energy’s involvement.

Xcel Energy also reserves the right to shut down testing activities if, in Xcel Energy's opinion or the opinion of Xcel Energy's designated representative, the Customer is using unsafe practices or is in violation of applicable local, state, or federal safety regulations. Xcel Energy requires compliance with the most conservative of the safety practices as provided by OSHA, NESC, or Xcel Energy's safety practices whenever work is being performed in an energized facility.

E. Testing Equipment

The Customer must provide all equipment necessary to perform the tests required by Xcel Energy. A list of testing equipment shall be submitted to Xcel Energy for approval prior to the beginning of the testing. Test instrument type (manufacturer, type, serial number) and associated calibration certifications shall be submitted to Xcel Energy prior to the commencement of any testing. The equipment certification shall be renewed at least annually and shall be traceable to the National Bureau of Standards. Xcel Energy will review the list and notify the Customer of any testing items that are not acceptable or are missing from the list. The Customer shall correct this deficiency prior to the start of testing.

Transmission System Guidelines	
 Xcel Energy	Xcel Energy Operating Companies
Interconnection Guidelines for Transmission Interconnected Customer Loads	Version: 13.0
<i>File Name:</i> XEL-POL-TransmissionInterconnectedCustLoads Version 13 - FINAL (10-2-23).docx	Page 32 of 49

F. Xcel Energy Supplied Equipment

Any Xcel Energy supplied equipment that is factory calibrated (transducers, pressure switches, tuners, etc.) shall be tested to verify calibration. The Customer may not modify calibration settings without authorization from Xcel Energy. If equipment does not meet specifications, the Customer should notify Xcel Energy of the problem immediately. Xcel Energy will then direct the Customer on how to proceed. If the Customer modifies factory settings without authorization, Xcel Energy will not be responsible for any costs associated with repair, replacement, or re-calibration of the Customer's equipment.

G. Final Design/As-built Documents

The Customer must at the time of demonstration testing have a complete set of construction drawings and documentation available. These documents should represent a complete set of information showing exactly how the facility has been built and the logic behind how the control systems will operate. The documents shall include but are not limited to one-line diagrams, meter, and relaying diagrams (M&R), AC and DC elementary diagrams (schematic drawings), circuit lists, Programmable Logic Controller (PLC) and relay logic, and any other appropriate or necessary information. Xcel Energy should be provided a duplicate copy of this documentation at least two weeks prior to demonstration testing. A coordination meeting with Xcel Energy should be held to clarify any questions on documentation or testing requirements before demonstration testing begins.

VI. OPERATION AND MAINTENANCE GUIDELINES

General guidelines will be stated below, but any specific guidelines will be defined in the Interconnection Agreement between the Xcel Energy operating companies and the Customer.

The Customer shall operate within the applicable guidelines of this document and any other specific requirements as stated in the Interconnect Agreement, the Power Purchase Agreement, the Transmission Services Agreement, or the Ancillary Services Agreement, as applicable.

A. Normal Conditions

The Customer must operate according to the instructions and approval given by the Xcel Energy Transmission Control Center personnel:

1. The Customer has twenty-four-hour support available.

B. Abnormal Conditions

Xcel Energy reserves the right to open the interconnection for any of the following reasons:

1. Xcel Energy line maintenance work on Xcel Energy System.
2. Xcel Energy substation maintenance on Xcel Energy System.
3. Xcel Energy System emergency.
4. Inspection of a Customer's substation equipment and protective equipment reveals a hazardous condition.
5. Failure of the Customer to provide maintenance and testing reports when required.

Transmission System Guidelines



Xcel Energy Operating Companies

Interconnection Guidelines for Transmission Interconnected Customer Loads

Version: 13.0

File Name: XEL-POL-TransmissionInterconnectedCustLoads Version 13 - FINAL (10-2-23).docx

Page 33 of 49

6. Customer's equipment interferes with other Xcel Energy customers or Customers or with the operation of Xcel Energy System.
7. Customer has modified the load facilities that affect Xcel equipment without the knowledge and approval of Xcel Energy or has not installed Xcel required protective devices.
8. Personnel or public safety are threatened.
9. Customer fails to comply with applicable OSHA Safety Tagging and Lockout requirements.
10. To address abnormal frequency or voltage issues or power quality issues determined by Xcel Energy to be adversely impacting the Xcel Energy system due to conditions on the interconnecting party's system or facilities.

Changes to the Xcel Energy System or the addition of other Customers or generation in the vicinity may require modifications to the interconnection protective devices. If such changes are required, the Customer may be subject to future charges for these modifications.

C. Energization of Xcel Energy Equipment by the Customer

The Customer must not energize a de-energized Xcel Energy circuit (unless specifically authorized and requested by Xcel Energy).

D. Maintenance Notification

The Customer must notify Xcel Energy or the ISO as provided for in the applicable OATT of any unusual conditions including, but not limited to the following:

1. Partial operating capability due equipment limitations.
2. Scheduled outage periods and return to service expectations. Return to service notification must be updated daily to reflect the recent progress or the lack of progress.

E. Maintenance

Interconnection protective devices owned by the Customer should be maintained and inspected according to manufacturer recommendations and/or industry standards. Procedures must be established for visual and operational inspections. Provisions should be established for equipment maintenance and testing. Equipment should include, but not be limited to:

1. Power Transformers
2. Circuit Breakers
3. Protective Relays
4. Station Batteries
5. Instrument transformers
6. Communication equipment (including channels)

Xcel Energy maintains the right to review the maintenance, calibration, and operation data of all protective equipment for protecting Xcel Energy facilities, customers, and other Customers. The Customer is responsible for providing the necessary test accessories (such as relay test plugs, instruction manuals, wiring diagrams, etc.) required to test these protective devices. Verification testing may include the tripping of the intertie breaker. If Xcel Energy performs work on the premises of the Customer, Xcel Energy operating personnel may make an

Transmission System Guidelines	
 Xcel Energy	Xcel Energy Operating Companies
Interconnection Guidelines for Transmission Interconnected Customer Loads	Version: 13.0
<i>File Name:</i> XEL-POL-TransmissionInterconnectedCustLoads Version 13 - FINAL (10-2-23).docx	Page 34 of 49

inspection of the work area. If hazardous working conditions are detected, the Customer must correct the unsafe conditions before Xcel Energy personnel will perform their work.

F. Design Changes After Commercial Operation

Any modifications to the Interconnection impacting Xcel Energy protective relaying and interlocks after the date of commercial operation must be reviewed and approved by Xcel Energy prior to implementing any changes. Demonstration of Relay Calibration, Trip Tests, and On-Line Tests may be required depending on the extent of the design change. Setting changes of any interconnection protection or synchronizing device must be approved by Xcel Energy with a hard copy of the changes forwarded to the designated Xcel Energy representative. Any "Field Modification" or "As Built" AC/DC protection and synchronizing schematics associated with any Xcel Energy required interconnection device must be forwarded to the designated Xcel Energy representative.

G. Operating Data Submittals

The Customer must provide operating data and equipment modeling to Xcel Energy and/or the appropriate regional reliability organization to support the following:

1. NERC compliance program(s).
2. Regional Reliability Organization compliance program(s).
3. Federal, state, and local regulatory programs.

H. Operational Log

Customers must maintain an operating log at each Interconnection facility indicating changes in operating, maintenance outages, trip indications, or other unusual conditions found upon inspection.

I. Communication With Xcel Energy Operations

The Xcel Energy representative will provide the Customer with the names and telephone numbers of the Xcel Energy Control Center and Operations Coordination personnel responsible for Xcel Energy System at the interconnection. The Customer will provide Xcel Energy with the names and telephone numbers of the personnel with responsibility for operating the load facilities.

The contact(s) of the Customer should include at least one 24/7-telephone number. Contacts should be able to provide information on equipment status, explanation of events on the Customer's equipment, and relay target and alarm information when asked to do so by Xcel Energy personnel. In addition, the Customer should contact Xcel Energy whenever:

1. Problems with the Interconnection are detected that could result in mis-operation of Interconnection protection or other Interconnection equipment.
2. The Interconnection opened by protective relay action.
3. Interconnection equipment problems result in an outage to a portion of the Xcel Energy System.
4. The Customer intends to initiate switching to close the interconnection.
5. The Customer intends to initiate switching to open the interconnection.

Transmission System Guidelines



Xcel Energy Operating Companies

Interconnection Guidelines for Transmission Interconnected Customer Loads

Version: 13.0

File Name: XEL-POL-TransmissionInterconnectedCustLoads Version 13 - FINAL (10-2-23).docx

Page 35 of 49

VII. GLOSSARY

Alternating Current (AC): That form of electric current that alternates or changes in magnitude and polarity (direction) in a regular pattern for a given time period.

Ampere: The unit of current flow of electricity. It is to electricity as the number of gallons per minute is to the flow of water. One-ampere (**A**) flow of current is equal to one coulomb per second flow.

ANSI: American National Standards Institute.

Apparent Power: For single-phase power, the current in amperes multiplied by the voltage equals the apparent power in volt-amperes (**VA**). Apparent power for 3-phase power equals the phase to neutral voltage multiplied by the line current multiplied by 3.

ATP (Alternate Transients Program): A digital computer modeling program that is typically utilized for performing high frequency lightning and/or switching induced transient power system studies. This is similar to EMTP and is not supported by the Electric Power Research Institute (EPRI).

Automatic: Self-acting, operated by its own mechanism when actuated by some impersonal influence as, for example, a change in current strength; not manual; without personal intervention.

Automatic Reclosing: A circuit breaker has automatic reclosing when means are provided for closing without manual intervention after it has tripped under abnormal conditions.

Balancing Area: A balance area is an electrical system bound by interconnect (tie-line) metering and telemetry and which regulates its generation in order to maintain its interchange schedule with other systems, contributes to frequency regulation of the Interconnection, and fulfills its obligations and responsibilities in accordance with NERC and reliability region (such as MRO, SPP, or WECC) requirements.

Balancing Area Operator: An individual charged with the operation of a balance area.

Capacity: The number of amperes of electric current a wire will carry without becoming unduly heated; the maximum ability of a machine, apparatus, or device under existing service conditions; the load for which a transformer, transmission circuit, apparatus, station, or system is rated.

CAPE (Computer-Aided Protection Engineering): CAPE is a productivity tool developed by Electrocon under the initial sponsorship of ten major U.S. electric utilities used predominately for modeling electric system data and coordinating electric system protective devices.

Circuit: A conducting path through which an electric current is intended to flow.

Circuit Breaker: A device for interrupting a circuit between separable contacts under normal or fault conditions. The interrupting ability of the device is normally rated or sized such that it exceeds the maximum fault current that is available at the location of application.

Control Contactors: Switching devices utilized to start or stop power system equipment, normally large motors.

CT (Current Transformer): A transformer intended for metering, protective, or control purposes and which is designed to have its primary winding connected in series with a circuit carrying the current to be measured or

Transmission System Guidelines



Xcel Energy Operating Companies

Interconnection Guidelines for Transmission Interconnected Customer Loads

Version: 13.0

File Name: XEL-POL-TransmissionInterconnectedCustLoads Version 13 - FINAL (10-2-23).docx

Page 36 of 49

controlled. A current transformer normally reduces current magnitudes to levels which can be handled by control, protection, and metering equipment. A CT secondary circuit must never be open-circuited while energized.

Current: A flow of electric charge measured in amperes (**A**).

Customer: Party requesting to interconnect with Xcel Energy System.

Demand: The rate at which electric power is delivered to or by a system; normally expressed in kilowatts (**kW**), megawatts (**MW**), or kilovolt-amperes (**kVA**).

Disconnect: A device used to isolate a piece of equipment and which has a minimal ability or no ability to interrupt current. A disconnect may be gang-operated (all poles switched simultaneously) or individually operated.

Dynamic Voltage Excursion: Transient change in system voltage magnitude, typically associated with a condition following clearing a system short-circuit or fault.

EMS (Energy Management System): The computer system Xcel Energy uses to provide real-time status and remote control of its electrical transmission system.

EMTP (Electromagnetic Transients Program): A digital computer modeling program that permits the analysis of the transient behavior of electrical networks. This program is presently supported by Electric Power Research Institute (EPRI).

Energy Losses: The general term applied to energy lost in the operation of an electrical system. Losses can be classified as Transformation Losses, Transmission Line Losses, or System Losses.

ERO (Electric Reliability Organization): The FERC designated electric reliability organization formed as prescribed in the Energy Policy Act of 2005. NERC is the current ERO. NERC has established reliability standards, and provide for enforcement of those standards.

Facilities Study: A study conducted by the Transmission Provider or a qualified third-party consultant for the Customer which is reviewed and approved by Transmission Provider to determine a list of facilities, the cost of those facilities, and the time required to interconnect the Customer Facility with the Transmission Provider's Transmission System.

FERC (Federal Energy Regulatory Commission): (Formerly the Federal Power Commission, or FPC.) FERC is an independent body within the Department of Energy (DOE) regulating interstate transmission and the prices of electricity and natural gas. It also licenses hydroelectric projects and regulates interconnections, construction work in progress, rates for wholesale Customers, utility accounting practices, and procedures.

Frequency: The number of alternating cycles occurring in a given interval of time (usually one second) in an electric current or voltage. Frequency is commonly expressed in hertz (**Hz**).

Fuse: A short piece of conducting material of low melting point, which is inserted in a circuit for the purpose of opening the circuit when the current reaches a certain value.

Ground: A term used in electrical work in referring to the earth as the zero potential conductor or reference plain. For safety purposes, circuits are grounded while any work is being done on or near a circuit or piece of equipment in the circuit. This is usually called protective or safety grounding.

Transmission System Guidelines



Xcel Energy Operating Companies

Interconnection Guidelines for Transmission Interconnected Customer Loads

Version: 13.0

File Name: XEL-POL-TransmissionInterconnectedCustLoads Version 13 - FINAL (10-2-23).docx

Page 37 of 49

Hertz (Hz): The term denoting frequency. Historically, frequency was referred to as cycles per second.

IEEE: Institute of Electrical and Electronics Engineers, Inc.

Incoming Breaker: The Customer-owned breaker that connects the Xcel Energy source of power to the bus of the Customer.

Interconnection Facilities: The facilities required to make the physical connection between the Customer's facility and the Xcel Energy transmission system. This may include new substation and transmission facilities as well as other system upgrades to be owned by Xcel Energy.

Interruption: A temporary discontinuance of the supply of electric power.

IPP (Independent Power Producer): An organization that is not a utility and that operates a power plant that produces energy and sells it to a utility.

Island: A part of an interconnected system that may become isolated from the rest of the system during a system disturbance and start operating as a subsystem with its own generation, transmission, and distribution capability. The islanded system and the main interconnected system may operate at different frequencies and voltages.

ISO (Independent System Operator): Entities corporately separate from the owners of transmission and other power market participants approved by FERC to direct the operation of the transmission system.

ITC (Independent Transmission Company): Entities corporately separate from the owners of transmission and other power market participants approved by FERC to direct the operation of the transmission system.

Kilovolt (kV): One thousand volts.

Kilovolt-Ampere (kVA): One-thousand-volt ampere. See the definition for Apparent Power.

Kilowatt (kW): An electric unit of power that equals 1,000 Watts.

Lagging Power Factor: Occurs when reactive power flows in the same direction as real power.

Leading Power Factor: Occurs when reactive power flows in the opposite direction of real power.

Line Losses: Electrical energy converted to heat in the resistance of all transmission and/or distribution lines and other electrical equipment.

MISO (Midcontinent Independent System Operator): A FERC-approved ISO corporately independent of Xcel Energy and to whom Xcel Energy has turned over the operations authority of its transmission system. The MISO will operate much of the transmission system from Minnesota, Wisconsin, Iowa, Illinois, Pennsylvania, Kentucky, and Missouri.

Megavolt-Ampere (MVA): One-million-volt ampere. See definition for Apparent Power.

Megawatt (MW): An electrical unit of power that equals one million watts.

MRO (Midwest Reliability Organization): A NERC Regional Entity operating in one reliability region.

Transmission System Guidelines



Xcel Energy Operating Companies

Interconnection Guidelines for Transmission Interconnected Customer Loads

Version: 13.0

File Name: XEL-POL-TransmissionInterconnectedCustLoads Version 13 - FINAL (10-2-23).docx

Page 38 of 49

NERC (North American Electric Reliability Corporation): NERC is the Electric Reliability Organization (ERO) responsible for establishing and enforcing the Reliability Standards to assure the reliability of the NERC defined Bulk Electric System. NERC has delegated certain authority for Reliability Standard Enforcement to the Regional Entities in the NERC Reliability Regions (SPP, WECC, and MRO).

OATT (Open Access Transmission Tariff): The FERC approved tariff for provision of transmission service to the Customer.

On-Line Testing: Testing typically performed as part of commissioning a new generation facility, specifically as it pertains to energized equipment ultimately operating in parallel / interconnected with the power system.

One-Line Diagram: A diagram in which several conductors are represented by a single line and in which various devices or pieces of equipment are denoted by simplified symbols. The purpose of such a diagram is to present an electrical circuit or circuits in a simple way so that their function can be readily grasped.

Parallel Operation: The operation of a Customer-owned generator while connected to the utility's grid. Parallel operation may be required solely for the operating convenience of the Customer, or for the intentional interchange of power with the utility's grid.

Peak Load: The maximum electric power consumed in a stated period.

Point of Change of Ownership (PCO): The point where the Customer's Interconnection Facilities connect to Xcel Energy's Interconnection Facilities.

Point of Energy Exchange: The point in the delivery system where one party takes delivery of the energy from the other party. This point is defined in the contract between Xcel Energy and the Customer. It is usually the point where facility ownership changes. For transmission-connected Customers, this is usually at a location at the transmission voltage level. This is often referred to as the POI or POD.

Point of Interchange: See Point of Energy Exchange.

Point of Interconnection (POI): The point where the Interconnection Facilities connect to the Transmission Provider's Transmission System.

Power (Actual, Active, or Real Power): The time rate of transferring or transforming energy or the power that accomplishes work, measured in Watts.

Power Factor (PF): The ratio of actual power (kW) to apparent power (kVA).

Power Flow: One-way power flow is the condition where the flow of power is entirely into or out of the facility of the Customer. Two-way power flow is the condition where the net flow of power may be either into or out of the facility depending on the operation of the generator and other Customer load.

Professional Engineer (P.E.): A licensed professional engineer registered with the appropriate state agency.

Programmable Logic Controller (PLC): A special form of micro-processor-based controller that uses a programmable memory to store instructions ("ladder logic"), and to implement functions such as logic sequencing, timing, and arithmetic in order to control machines and processes.

PSCAD: A transient analysis software program, similar to ATP and EMTP.

Transmission System Guidelines	
 Xcel Energy	Xcel Energy Operating Companies
Interconnection Guidelines for Transmission Interconnected Customer Loads	Version: 13.0
<i>File Name:</i> XEL-POL-TransmissionInterconnectedCustLoads Version 13 - FINAL (10-2-23).docx	Page 39 of 49

Protection: All of the relays and other equipment that are used to open the necessary circuit breakers and fuses to automatically clear or disconnect lines or equipment when trouble develops.

PSCAD - A transient analysis software similar to EMTP and ATP programs. PSCAD is a registered trademark of Manitoba HVDC research center Inc.

Reactive Power (Var): The power that oscillates back and forth between inductive and capacitive circuit elements without ever being used. The function of reactive power is to establish and sustain the electric and magnetic fields that are required to perform useful work in AC systems.

Relay: A device that is operated by a variation in the condition of one electric circuit to affect the operation of another device in the same or in another electric circuit.

Remote Terminal Unit (RTU): A device installed at a substation or generation facility, and at an XE Operations Control Center, and is used to provide communication for remote control and indication of substation or generation facility equipment from the XE Operations Control Center.

Regional Entities (RE): Expected to replace the RRO after the implementation of the Electric Reliability Organization.

RRO (Regional Reliability Organization): The entity under the authority of NERC responsible for the reliable operation and use of the electric power system within a specific geographic region.

RTO (Regional Transmission Operator): Entities corporately separate from the owners of transmission and other power market participants approved by FERC to independently direct the operation of the transmission system.

SPP (Southwest Power Pool): SPP operates as an RTO. The SPP RTO performs the independent transmission functions required of that entity. The SPP RTO has a Pool-Wide Tariff under which Xcel Energy has placed the SPS operating area. This tariff governs generator interconnection requests and provides network and point-to-point transmission service. SPP Operates in portions of Texas, New Mexico, Oklahoma, Kansas, Nebraska, Missouri, Arkansas, Louisiana, Iowa, Colorado, Utah, Arizona, Wyoming, and Montana.

Station Power: The electric power used for the heating, lighting, air-conditioning and office equipment needs of the buildings on a Generation Facility's site, and for operating the electric equipment that is on the Generating Facility's site.

Station Service: The electric energy needs of the Transmission Provider's substation equipment.

Switch: A device for making, breaking, or changing the connections in an electric circuit.

System: The entire generating, transmitting, and distributing facilities of an electric system.

Transformer: An electric device, without continuously moving parts, in which electromagnetic induction transforms electric energy from one circuit to one or more other circuits at the same frequency, usually with changes in the magnitudes of the voltage and current.

Transient Network Analysis (TNA): A digital computer modeling program that permits the analysis of the transient behavior of electrical networks.

Transmission System Guidelines	
 Xcel Energy	Xcel Energy Operating Companies
Interconnection Guidelines for Transmission Interconnected Customer Loads	Version: 13.0
<i>File Name:</i> XEL-POL-TransmissionInterconnectedCustLoads Version 13 - FINAL (10-2-23).docx	Page 40 of 49

Transmission Owner: An entity that owns, leases or otherwise possesses an interest in the portion of the Transmission System at the Point of Interconnection and may be a Party to the Interconnection Agreement to the extent necessary.

Transmission Provider: The public utility (or its designated agent) that owns, controls, or operates transmission or distribution facilities used for the transmission of electricity in interstate commerce and provides transmission service under the OATT. The Transmission Provider includes the Transmission Owner when the Transmission Owner is separate from the Transmission Provider.

Utility Grade Relays: Relays that meet IEEE C37.90, C37.90.1, C37.90.2, and C37.90.3.

Var: Volt-ampere reactive, see Reactive Power.

Var Capability Testing: Testing performed with a generation facility interconnected with the XE power system in order to verify or determine the generation facility's net reactive power (Var) output and corresponding power factor, typically as measured at the PoI.

Voltage: Electric potential or potential difference expressed in volts (**V**).

Volt-Ampere: A unit of apparent power (**VA**) in an alternating-current circuit.

VT (Voltage Transformer): A transformer intended for metering, protective, or control purposes and which is designed to have its primary winding connected either between the primary conductors to be measured or between a conductor and ground. A voltage transformer normally reduces voltage magnitudes to levels which can be handled by control, protection, and metering equipment. The historic term for a VT is potential transformer.

Watt-Hour: A unit of work or energy equivalent to the power of one Watt operating for one hour (**Wh**).

WECC (Western Electric Coordination Council): A NERC Regional Entity operating in the Western Grid reliability region. WECC serves both as an organization of power suppliers in the Western States that plans for power availability by coordinating power exchanges between members and as a NERC delegated Regional Entity responsible for the development of regional reliability standards and for the Enforcement of NERC Reliability Standards and its own regional standards. WECC's current members include investor-owned companies such as Xcel Energy, municipal systems, rural cooperatives, the Western Area Power Administration, Bonneville Power Administration, and the US Bureau of Reclamation. All operating in the Western Interconnection.

Wye or "Y" Connected Circuit (Star Connected): A three-phase circuit in which windings of all three phases have one common neutral point connection.

VIII. REFERENCES

The following list of references has been utilized in preparation of this document and/or should be consulted for further information/clarification. When the following publications/standards are superseded by an approved revision, the latest revision shall apply.

ANSI C2-2002, National Electrical Safety Code.

ANSI C84.1-1995 (R2005), Electric Power Systems and Equipment - Voltage Ratings (60HZ).

IEEE Std. C37.106™ –2003, IEEE Guide for Abnormal Frequency Protection for Power Generating Plants,

ANSI/ IEEE C37.90-1989, IEEE Standard for Relays and Relay Systems Associated with Electric Power Apparatus.

IEEE Std C37.90.1-2002™ – 2002, IEEE Standard for Surge Withstand Capability (SWC) Tests for Relays and Relay Systems Associated with Electric Power Apparatus.

IEEE Std C37.90.2™-2004, IEEE Standard for Withstand Capability of Relay Systems to Radiated Electromagnetic Interference from Transceivers.

IEEE Std C37.90.3-2001, IEEE Standard Electrostatic Discharge Tests for Protective Relays.

IEEE Std C37.95™ – 2002, IEEE Guide for Protective Relaying of Utility-Consumer Interconnections.

IEEE Std 80-2000, IEEE Guide for Safety in AC Substation Grounding.

IEEE Std-142-1991, IEEE Recommended Practice for Grounding of Industrial and Commercial Power Systems – IEEE Green Book (Color Book Series).

IEEE Std-242-2001, IEEE Recommended Practice for Protection and Coordination of Industrial and Commercial Power Systems – IEEE Buff Book (Color Book Series).

IEEE Std-446-1995, IEEE Recommended Practice for Emergency and Standby Power Systems for Industrial and Commercial Applications – IEEE Orange Book (Color Book Series).

IEEE 519-1992, IEEE Recommended Practices and Requirements for Harmonic Control in Electrical Power Systems.

IEEE 1453™-2004, IEEE Recommended Practice for Measurement and Limits of Voltage Fluctuations and Associated Light Flicker on AC Power Systems

IEEE Std-1100-1999, IEEE Recommended Practice for Powering and Grounding Electronic Equipment – IEEE Emerald Book (Color Book Series).

NERC Reference Document, Reliability Considerations for Integrating Non-Utility Generating Facilities with the Bulk Electric Systems, April 1987, North American Electric Reliability Corporation, Princeton, NJ 08540.

Transmission System Guidelines



Xcel Energy Operating Companies

Interconnection Guidelines for Transmission Interconnected Customer Loads

Version: 13.0

File Name: XEL-POL-TransmissionInterconnectedCustLoads Version 13 - FINAL (10-2-23).docx

Page 42 of 49

NERC Document, Integrating Non-Utility Generators - Reliability Considerations for Integrating Non-Utility Generating Facilities with the Bulk Electric Systems, January 1992, North American Electric Reliability Corporation, Princeton, NJ 08540.

NERC/WECC Planning Standards September 1997.

NFPA 70- 2005, National Electrical Code

OSHA Safety Tagging and Lockout Procedures.

Standardization of Generation Interconnection Agreements and Procedures," Order No. 2003, Fed. Reg. Vol. 68, No. 160 (August 19, 2003).

WSCC Coordinated Off-nominal Frequency Load Shedding and Restoration Plan (Final Report November 25, 1970), prepared by the Under-frequency Issues Workgroup, WSCC Technical Studies Subcommittee.

Xcel Energy document "XEL-STD-Criteria for Engineering and Design of Substations-Physical.doc"

Xcel Energy document TCS-3 "Transmission Criteria for Substations: Protective Relaying and Control"

Xcel Energy document TCS-4 "Testing Criteria"

APPENDIX A: Typical Interconnection Configuration

TRANSMISSION TO LOAD INTERCONNECTIONS

Figure 1 - Typical Interconnection To Existing Transmission Line

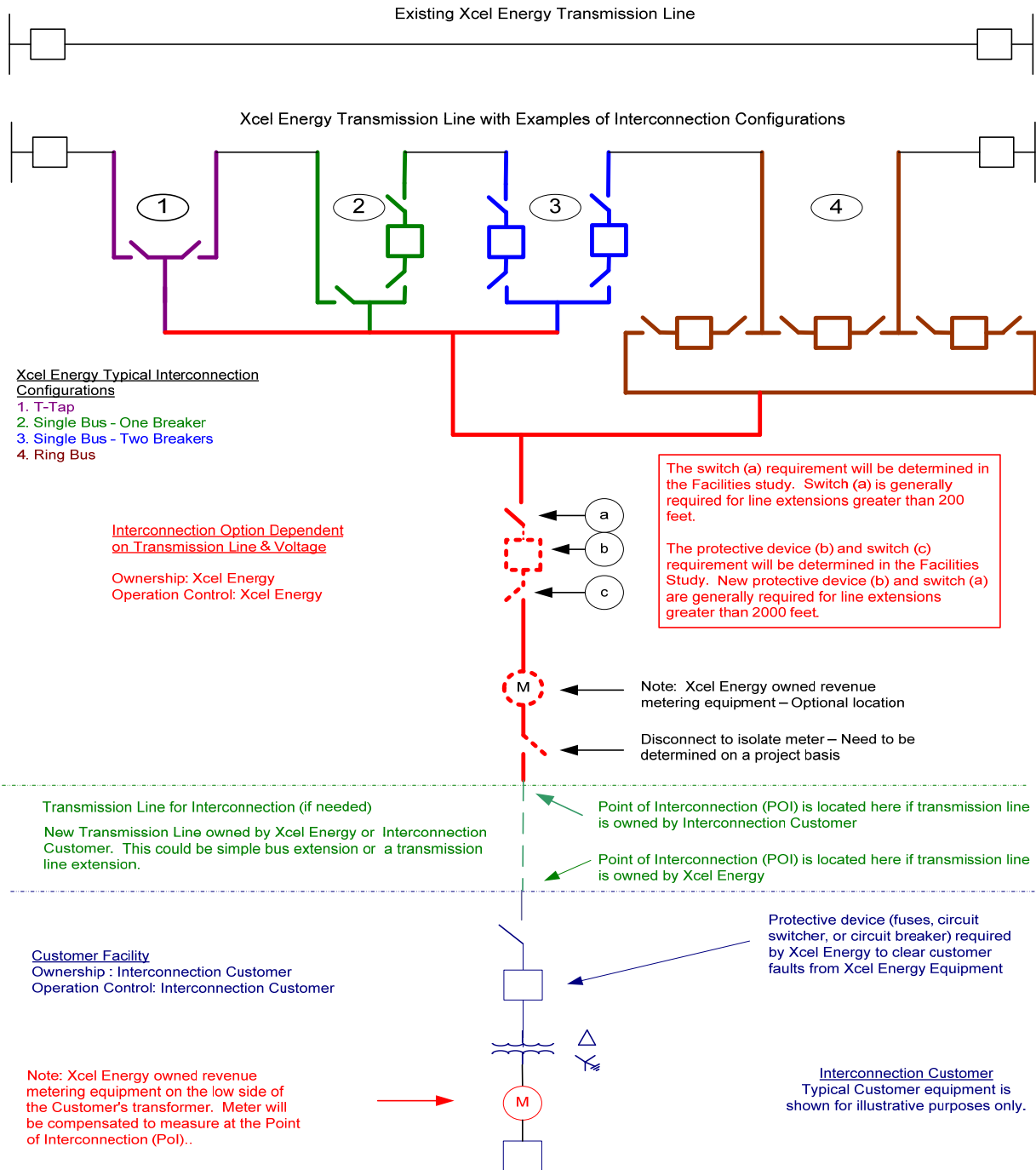

Customer Facility
Ownership : Interconnection Customer
Operation Control: Interconnection Customer

TRANSMISSION TO LOAD INTERCONNECTIONS

Figure 2: Typical Interconnection To Existing Substations

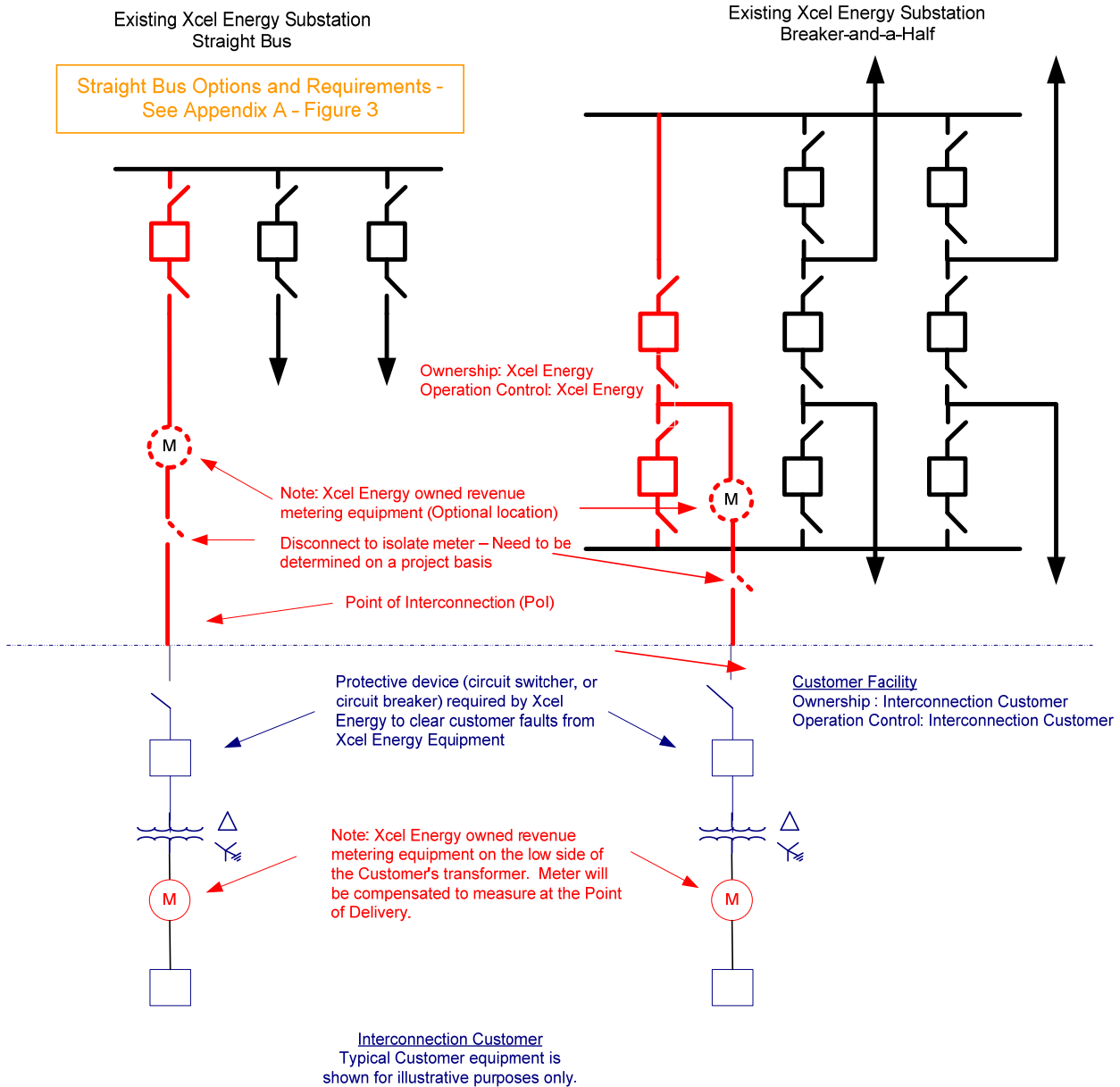

Interconnection Guidelines for Transmission Interconnected Customer Loads

Version: 13.0

File Name: XEL-POL-TransmissionInterconnectedCustLoads Version 13 - FINAL (10-2-23).docx

Page 45 of 49

TRANSMISSION TO LOAD INTERCONNECTION - STRAIGHT BUS
Figure 3 - Straight Bus Requirements

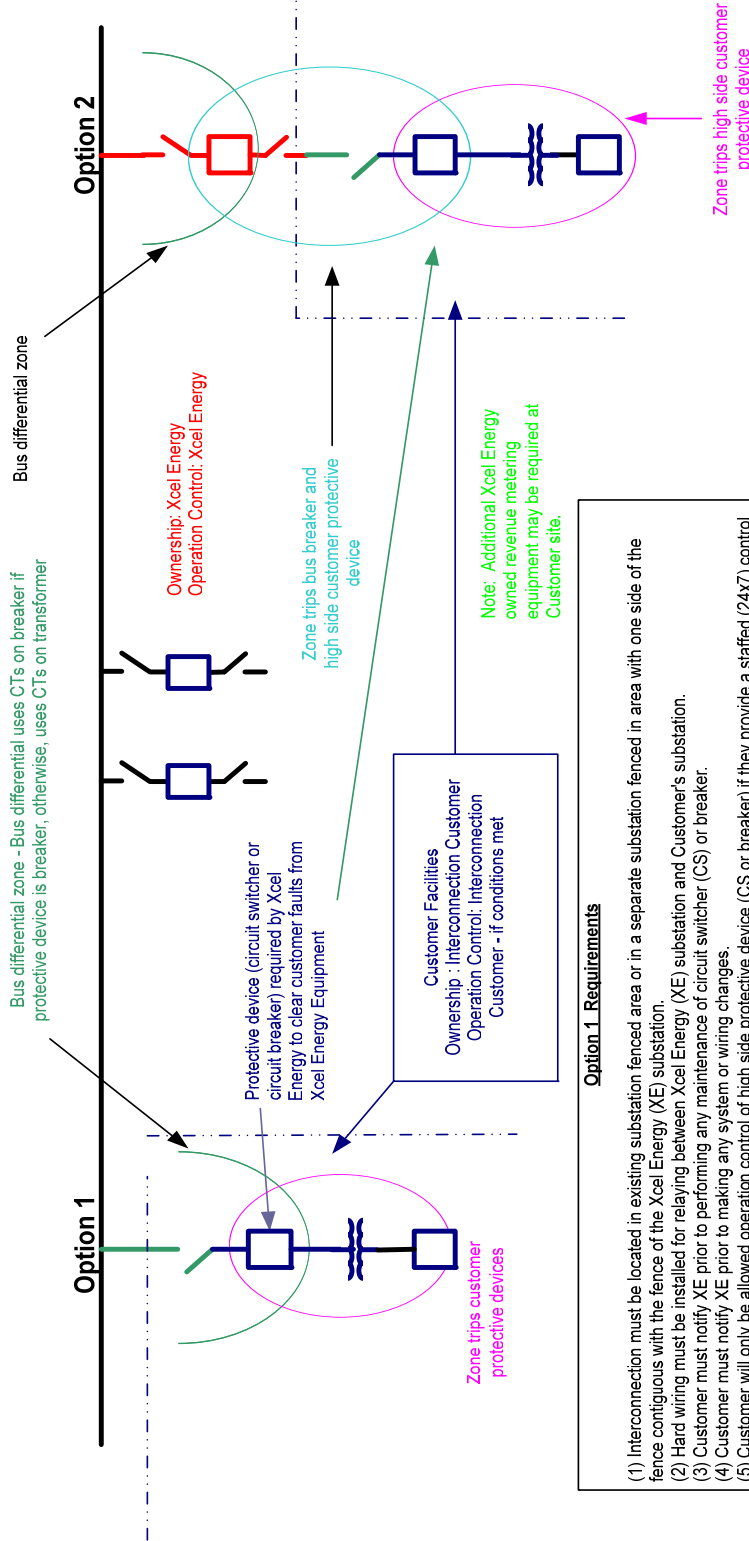

Option 2 - Requirements

- (1) will be used if option 1 requirements can not be met.
- (2) Customer will be financially responsible for the breaker connected directly to Xcel Energy straight bus.

Option 1 - Requirements

- (1) Interconnection must be located in existing substation fenced area or in a separate substation fenced in area with one side of the fence contiguous with the fence of the Xcel Energy (XE) substation.
- (2) Hard wiring must be installed for relaying between Xcel Energy (XE) substation and Customer's substation.
- (3) Customer must notify XE prior to performing any maintenance of circuit switcher (CS) or breaker.
- (4) Customer must notify XE prior to making any system or wiring changes.
- (5) Customer will only be allowed operation control of high side protective device (CS or breaker) if they provide a staffed (24x7) control center for operations.
- (6) High side switch must be gang operated (preferably motor operated) and have dual controls.
- (7) Customer must provide adequate assurances that both sides will communicate any changes to gang switch status before operating switch.
- (8) Customer will be responsible for maintenance of the CS or breaker.
- (9) Customer will provide XE with a & b contacts from the CS or breaker as required to facilitate relaying.
- (10) Customer is required to install a breaker failure relay and provide a trip contact from the relay to XE. This contact must be isolated whenever the customer is working on their relaying or wiring. XE will provide trip contact(s) from their relaying.
- (11) All customer relaying associated with the CS or breaker must have test switches installed to facilitate testing of the relaying (trip contacts, CT's, P.T's, etc.).
- (12) XE reserves the right to witness all testing of the protection system that interfaces with XE.
- (13) Customer must provide 2 sets of CT's for exclusive use by XE (primary and back-up relaying). If a breaker is used the CT's need to be on the transformer side of the breaker. If a CS is used the CT's shall be the 2 high side CT's closest to the transformer. Customer CT's utilized by XE will need to exactly match XE CT's and the customer will need to contact XE for specifics. Note: In some locations only one CT will be required, but, unless otherwise directed by XE, customer should plan on 2 sets of CT's.
- (14) CT circuits being provided will not contain any splices. Customer and XE will work together on the physical installation of the circuits between the two control buildings.
- (15) XE will test CT circuits for continuity, etc., upon installation or after any modification.

Transmission System Guidelines	
 Xcel Energy	Xcel Energy Operating Companies
Interconnection Guidelines for Transmission Interconnected Customer Loads	Version: 13.0
<i>File Name:</i> XEL-POL-TransmissionInterconnectedCustLoads Version 13 - FINAL (10-2-23).docx	Page 46 of 49

APPENDIX B: Xcel Energy Metering and Telemetry Requirements

1. General

The information in Appendix B outlines the requirements that shall apply for interconnecting the Customer to the Xcel Energy System. In those cases where the Power Purchase Agreement, Interconnection Agreement, or Ancillary Services Agreement provisions differ from these requirements, the contract provisions shall take precedence.

The meter installation will be capable of measuring Real Demand (Watts, kW, or MW), Reactive Demand (vars, Kvars, or Mvars), Voltage (V or kV), Current (A), Real Energy (Whr, kWhr, or MWhr), Reactive Energy (var-hours, kvar-hours, or Mvar-hours), and possibly harmonics (voltage and current when required). The metering shall have memory capable of a minimum of 4-channel, hourly data recording for 37 days. Additional channels for data recording may be required at the discretion of Xcel Energy (XE). The metering installation will normally have remote dial-up data-retrieval capability. The XE required billing (revenue) meter, power quality metering (if required), instrument transformers (CTs, VTs) will be specified and owned by XE, but instrument transformers may be purchased and installed by the Customer or XE, as identified during the project design phases, and determined on a case-by-case basis. XE will furnish meter and programs according to XE specifications.

2. Metering Accuracy, Testing, and Repair

A. METERING ACCURACY – REVENUE METERING

The metering shall have an accuracy of $\pm 0.5\%$. Any current or voltage transformers that are used for metering will adhere to the "Accuracy Classifications for Metering" listed in ANSI C57.13. XE requires 3-element metering accuracy for all circuits. The Voltage Transformers (VT) and Current Transformers (CT) must be metering accuracy class devices. Metering CTs and VTs are required to be independent of the protection system CTs. As long as the burden is not determined by XE to be excessive, additional secondary windings on the VTs can be used for other purposes such as protective relaying. All of these VT secondary supplies used for non-revenue metering purposes (e.g. relaying) shall be separately fused from the metering VT secondary supplies.

All voltage and current transformers used for interconnect metering with continuous flows less than 20% of full-scale nameplate rating of the current transformers shall conform to $\pm 0.15\%$ metering accuracy class or better. All current transformers shall conform to ANSI metering accuracy class $\pm 0.3\%$ for Burdens B0.1 thru B1.8 and shall have a continuous current thermal rating factor (TRF) sized appropriately for the application. All voltage transformers shall meet ANSI metering accuracy class $\pm 0.3\%$ for all standard burdens. Note that the metering used for local (panel) and remote (SCADA) indication and monitoring purposes does not typically need to conform to the higher accuracy requirements of the revenue metering, and are typically supplied from the relaying accuracy CTs (bushing CTs), CVTs, etc.

B. PERIODIC TESTING

The metering equipment shall be tested periodically, and re-calibrated or replaced to maintain the required accuracy. The meter testing frequency shall at a minimum be based on current XE Practices and State or Federal regulations. XE's present testing practices are based on the type of metering situation and the jointly agreed to requirements of both parties involved. The Customer, at its option, may witness in the periodic testing. If the proposed date is not acceptable, then an alternative time acceptable to both parties must be

Transmission System Guidelines	
 Xcel Energy	Xcel Energy Operating Companies
Interconnection Guidelines for Transmission Interconnected Customer Loads	Version: 13.0
<i>File Name:</i> XEL-POL-TransmissionInterconnectedCustLoads Version 13 - FINAL (10-2-23).docx	Page 47 of 49

worked out. The owner of the meter shall analyze and distribute any maintenance, repair, and test results to all parties receiving the meter readings per the request of such parties.

C. METER AND TELEMETRY EQUIPMENT REPAIR

The owner of the metering and telemetry equipment is responsible for ensuring that the equipment is adequately maintained and is repaired within a reasonable time after a failure is detected. The repair or replacement of a defective meter must be completed within 1 business day after it has been detected. All changes, repairs, and replacements of the meter must be coordinated with the XE Meter Department.

3. Metering and Telemetry Function Requirements

The meter and telemetry requirements define XE’s required functionality for meters, metering related equipment (telephone lines, current transformers, voltage transformers, etc.), and telemetry equipment (Remote Terminal Units [RTUs], transmitters, receivers, etc.). Major factors generally used to determine the type of metering and telemetry required include:

- a) The type and size of the customer’s equipment.
- b) The location of the customer on the XE System.
- c) The manner in which the installation will operate (one-way vs. two-way power flow).
- d) Customer with distribution generation connected
- e) Customer desire to have other than XE provide ancillary services

Each request will be handled individually, and XE will solely determine the metering and telemetry modifications and/or additions required. All Transmission-to-Load interconnections will require a RTU circuit for the installation of an RTU, Dual-Port RTU, Mini RTU, or any device that can provide this RTU functionality for Xcel Energy Operations and Energy Accounting. At a minimum, the Customer will have to provide the Xcel Energy System Control Center real-time values for the MWs and Mvars from the revenue meter. ICCP data is not a substitute for RTU requirements. XE will work with the customer to achieve an installation that meets the requirements of both the customer and XE. The metering requirements and cost responsibility will be stated in the Interconnection Agreement.

In addition to providing real-time revenue meter values to the Xcel Energy System Control Center, the Customer must provide a phone line or other suitable communication channel to allow the revenue meter data to be periodically retrieved by Xcel Energy. This periodic retrieval will happen at least once per month.

If the Interconnection is outside XE’s balancing area, the utility within whose balancing area the interconnection resides may have specific metering and telemetry requirements to which the Customer must adhere. Upon the start of the Facilities Study, XE will notify the customer of any other utility who may need to be involved in the metering and telemetry design and approval. If the interconnection is not within either XE’s service territory or XE’s balancing area, the following metering and telemetry requirements may not apply

A. REAL-TIME MEASURED VALUES AND METERING REQUIRED

- Real Energy Usage (Watt-hours)
- Power factor or Reactive Energy Usage (Power Factor, VARhours, or Q-hours)

Interconnection Guidelines for Transmission Interconnected Customer Loads

Version: 13.0

File Name: XEL-POL-TransmissionInterconnectedCustLoads Version 13 - FINAL (10-2-23).docx

Page 48 of 49

- Interval Recorder to capture hourly energy use (some meters provide this capability within the meter and is an acceptable substitute)
- RTU functionality and communication circuit to provide these values to the Xcel Energy System Control Center.
- The ability and communication channel for XE to remotely interrogate the meter and data

B. ADDITIONAL MEASURED VALUES, METERING, AND TELMETRY WHEN REQUIRED

- Status of high side interrupting and/or disconnecting device
- Real Power Flow (Watts)
- Reactive Power Flow (VARs), at XE’s discretion
- Voltage (steady state 60 Hz and possibly transients) at the point of connection to XE (Volts), at XE’s discretion
- Amps at the point of connection to XE
- Harmonics – voltage and current (if PQM meter is required)
- Remote Terminal Unit or Data Link to telemeter all measured values to XE’s Energy Management System. This will also capture the hourly energy usage by reading the MWH values.

Recording and communication of the data to XE’s EMS through a dedicated communication medium a minimum of every 24 seconds.

C. METERING CONFIGURATION

The Typical Metering Installation (see Figure C-1) will be used when XE serves the load requirements of the Customer directly. Each specific situation will be evaluated for cost effective metering.

FIGURE C-1: TYPICAL METERING INSTALLATION – LOAD REQUIREMENTS SERVED BY XCEL ENERGY

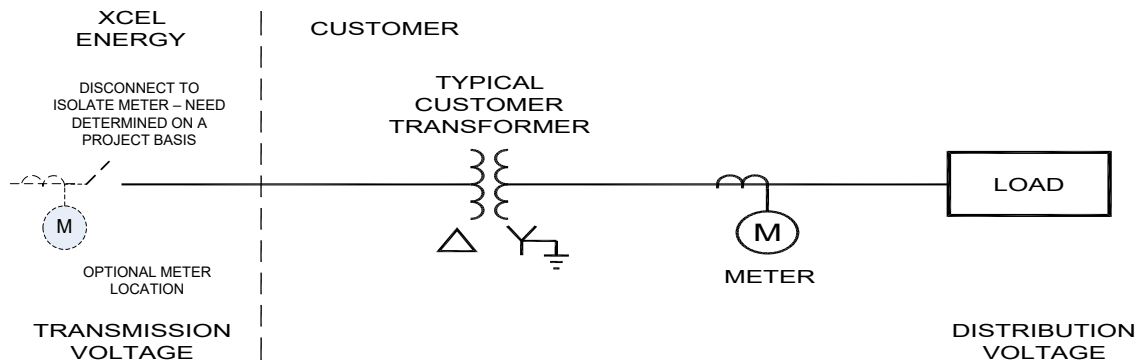

D. ENERGY LOSSES

If the energy is not measured at the point where the energy exchange between XE and the Customer has been defined by contract, energy losses must be determined. Accounting for the losses may be done either by attributing losses to the monthly accounting of exchanged energy or by attributing losses directly to the energy registered on the meter. Should a loss compensated meter be used, power transformer

Transmission System Guidelines



Xcel Energy Operating Companies

Interconnection Guidelines for Transmission Interconnected Customer Loads

Version: 13.0

File Name: XEL-POL-TransmissionInterconnectedCustLoads Version 13 - FINAL (10-2-23).docx

Page 49 of 49

performance test results and/or line impedances must be supplied to XE's Meter Engineering Department prior to installation.

E. AFTER THE METER READING

All Transmission Load Interconnection metering points will have recording devices that are capable of being interrogated by remote communication. XE has the ability to share an existing telephone line with the Customer, but it may be necessary to install a new communications line. The communications circuit cost (telephone lines, telephone charges, etc.) to allow remote reading of the meter at a non-XE facility is the responsibility of the Customer. Other communications options may be available for meter data retrieval, depending on service territory.